

User Manual

www.accuniq.com



ACCUNIQ

Adding accuracy to healthcare

User Manual
BC510



SELVAS 
Healthcare



The device bears the CE label in accordance with the provisions of Medical Device Directive 93/42/EEC.

THE PERSONS RESPONSIBLE FOR PLACING DEVICES ON THE EC MARKET UNDER MDD 93/42/EEC



SELVAS Healthcare, Inc.

155, Shinseong-ro, Yuseong-gu, Daejeon, 34109 Republic of Korea

TEL: 82-42-879-3000, FAX: 82-42-864-4462



VITAKO Sp. z o.o.

ul. Stanisława Żaryna 7c 02-593 Warszawa, POLAND

TEL: +48 505 522 888

CONTENTS

INTRODUCTION	5
1. INTENDED USE.....	5
2. WORD DEFINITIONS.....	5
3. CLASSIFICATION AND COMPLIANCE.....	6
4. SAFETY PRECAUTIONS.....	6
5. SAFETY SYMBOLS AND INFORMATION.....	11
6. Guidance for Electromagnetic compatibility(EMC)	13
ABOUT BODY COMPOSITION	18
TERM AND FUNCTION OF EACH PART	20
1. Basic Package	20
2. Options	21
3. Appearance of the device	23
INSTALLATION	26
1. Power Supply	26
2. Peripheral Device Installation	27
1) Connecting Computer	27
2) Connecting Printer	28
3) Connecting Blood Pressure Monitor	29
4) Connecting ultrasonic height meter	29
5) Replacing of thermal paper (OPTION)	30
SYSTEM SETUP	31
1. Entering SYSTEM SETUP	31
2. Menu in SYSTEM SETUP	31
3. Selecting a Menu in SYSTEM SETUP	32
4. Exiting SYSTEM SETUP	32
5. Moving to SYSTEM SETUP	32
6. Setup	33
INITIAL SCREEN SETTING	40
MEASUREMENT AND ANALYSIS	41
1. Precautions for Measurement	41
2. Correct Posture	42
3. Measurement	44

1) Basic Analysis	44
2) Analysis Using a height meter	48
3) Analysis Using Blood Pressure Monitor	49
STORAGE OF DATA USING USB MEMORY	50
PRINTING	52
RESULT INTERPRETATION	53
STORAGE & MAINTENANCE	57
ERROR & REPAIR	58
1. Kinds of Error & Repair	58
2. Error Occurrence & Repair	60
AFTER SERVICE	61
1. AFTER SERVICE	61
2. PACKING AND TRANSPORT	61
SPECIFICATION	62
WARRANTY	63
INSTRUCTIONS FOR ASSEMBLY	65
1. HOW TO INSTALL A DEVICE	65
2. ASSEMBLING A HEIGHT METER (OPTION)	70
3. ASSEMBLING AN Bluetooth (OPTION)	77
4. ASSEMBLING AN ANKLE ELECTRODE (OPTION)	80

INTRODUCTION

We highly appreciate that you chose our company's product.

You are kindly requested to be familiar with these directions before using this product and always keep it together with the product. In case you are not sure about any directions or problems arising while using the product, please contact our service center.

We will provide you with detailed instructions.

1. INTENDED USE

This device measures impedance by bioelectrical impedance analysis method and provides lots of information using measured impedance and inputted personal data (height, age, gender, weight).

It shows body composition of MBF, LBM, SLM, SMM, TBW, protein mass, mineral mass, etc. and information regarding BMI, PBF, BMR, abdominal analysis, Target to control, segmental analysis, Body composition change, etc.

2. WORD DEFINITIONS

To ensure safe operation and long term performance stability, it is essential that you fully understand the functions, operating and maintenance instructions by reading this manual before operating your unit.

Particular attention must be paid to all warnings, cautions and notes incorporated herein.

The following conventions are used throughout the manual to denote information of special emphasis.

Warning	"Warning" indicates important information about the presence of a hazard which may cause severe personal injury, loss of substantial property, damage if the warning is ignored.
	

Caution	"Caution" indicates important information about the presence of a hazard which may cause minor personal injury or property damage if the caution is ignored.
	

Note	"Notice" indicates important information in order to notify installation, operation or maintenance of this device. "Notice" is important but not hazard-related. Hazard warnings are not included here.
	





3. CLASSIFICATION AND COMPLIANCE

- 1) This device is classified as;
 - Class 1 type-BF against electric shock
 - Ordinary equipment without protection against ingress of water
 - Equipment not suitable for use in presence of a flammable anesthetic mixture by standard of EN 60601-1: 2006(Basic safety and essential performance of Medical Electrical Equipment)
- 2) This device is complied with Class A for Noise-Emission, Level B for Noise-immunity, by standard of IEC 60601-1-2:2007(Electromagnetic Compatibility Requirements).

4. SAFETY PRECAUTIONS

This device is designed and manufactured with consideration of the safety of the operator and subject and also the reliability of the unit.

The following warnings, precautions and notes must be observed for safety;

Warning 	During measurement of the body composition, a microcurrent of 180µA flows through the body. Individuals who have any kind of implanted active medical devices, such as pacemakers, should not use this equipment because the microcurrent can cause malfunction in the implanted device.
Warning 	To prevent fire hazard, use only a correctly wired (100-240VAC) outlet, and do not use a MSO(Multiple Socket Outlet) that is not in compliance with IEC 60601-1.
Warning 	To reduce the risk of electric shock or product damage, never plug-in or plug-out with wet hands.
Warning 	Physically disabled persons should not attempt to take measurements alone, but instead should have their caretakers assist them in using the device.
Caution 	The unit must be operated only by, or under supervision of a qualified person with our company or our distributors.

Caution

If you have experienced any trouble with the unit, switch it off immediately, and contact our company or its authorized dealer for assistance.

Caution

If you plan to connect any device from other manufacturers electrically or mechanically to the unit, contact our company or its authorized dealer for instructions before doing so.

When you connect computer or other system to the unit (RS-232C), the attached systems should be those certified by IEC 950 or equivalent standards for data processing equipment.

Configurations shall comply with the system standard EN 60601-1:2006.

Everybody who connects additional equipment to the signal input part or signal output part configures a medical system by standard EN 60601-1:2006.

If in doubt, consult the A/S department of local distributor.

Caution

Avoid the following environments for storage;

- Where the ambient temperature falls below -25°C or exceeds 70°C.
- Where the atmospheric pressure falls below 70kPa (700mbar) or exceeds 106kPa (1060mbar).
- Where the humidity is over 93% non-condensing.
- Where the unit is exposed to spray or splashing water.
- Where the unit is exposed to dust.
- Where the unit is exposed to water vapor.
- Where the unit is exposed to salty atmosphere.
- Where the unit is exposed to explosive gas.
- Where the unit is exposed to excessive shocks or vibrations.
- Where the angle of inclination of mounting surface exceeds 10 degrees.
- Where the unit is exposed to direct sunlight.

Caution

This device needs special precautions regarding EMC and needs to be installed and put into service according to the EMC information provided in the ACCOMPANYING DOCUMENTS.

Caution

Cross contamination is possible because this equipment is used with bare hands and feet. Refer to the cleaning and disinfecting methods in this manual.

Caution	Measurements may be impaired if this device is used near televisions, microwave ovens, X-ray equipment or other devices with strong electrical fields. To prevent such interference, use the meter at a sufficient distance from such devices or turn them off.
	

Prohibition	Do not disassemble or alter the device under any circumstances, as this could result in electric shock or injury as well as adversely affect the precision of measurements.
	This device is specified as Class 1 type BF unit under the standard EN 60601-1: 2006(Basic safety and essential performance of Medical Electrical Equipment). Therefore, patients must not touch or handle inner side of the system at any time.

Prohibition	Do not to touch signal input, signal output or other connectors, and the patient simultaneously.
	

Prohibition	The unit has previously been adjusted in the factory for optimum performance.
	Do not attempt to adjust switches or any other things except those specified in this manual for operation.

Prohibition	Never pour any liquid directly on the scale platform, as it may leak and cause internal damage..
	

Prohibition	Never jump on the Weighing Platform, there may be a risk of stumbling and malfunction of the equipment.
	

Note	This equipment has been tested and found to comply with the limits for medical devices according to IEC 60601-1-2:2007. These limits are designed to provide reasonable protection against harmful interference in a typical medical installation. This equipment generates uses and can radiate radio frequency energy and, if not installed and used in accordance with the instructions, may
	

cause harmful interference to other devices in the vicinity. However, there is no guarantee that interference will not occur in a particular installation. If this equipment does cause harmful interference to other devices, which can be determined by turning the equipment off and on, the user is encouraged to try to correct the interference by one or more of the following measures:

- Reorient or relocate the receiving device.
- Increase the separation between the equipment.
- Connect the equipment into an outlet on a circuit different from that to which the other device(s) are connected.
- Consult the manufacturer or field service technician for help.

Note



Place the Weighing Platform on a level and stable surface. If the equipment is used when the Weighing Platform is unstable because not all feet are on the surface, there may be a risk of stumbling or inaccurate measurement.

Note



Note that portable and mobile RF communications equipment can affect MEDICAL ELECTRICAL EQUIPMENT.

Note



Consult a physician or a trained health professional for interpretation of measurement results.

Note



In case of patients who have certain diseases, the estimates might be different.

Note

Incorrect operation or failure of user to maintain the unit spares the manufacturer or his agent of the responsibility for system's non-compliance with specifications or responsibility for any damage or injury.

This manual is made for informational purposes and this manual and product are not meant to be a substitute for the advice provided by your own physician or other medical expert. You should not use the information contained in the product for diagnosis or treatment of health problems or prescription of

medication by yourself. If you have or suspect that you have a medical problem, consult with your physician promptly.

Defective units or accessories must be packed in the replacement cartons to be shipped off from you to our company.

Shipping and insurance costs for return of defective unit must be prepaid by the users.

Caution



Measurements may be impaired if this device is used near televisions, microwave ovens, X-ray equipment or other devices with strong electrical fields. To prevent such interference, use the meter at a sufficient distance from such devices or turn them off.

Note



Incorrect operation or failure of user to maintain the unit spares the manufacturer or his agent of the responsibility for system's non-compliance with specifications or responsibility for any damage or injury.

This manual is made for informational purpose and this manual and product are not meant to be a substitute for the advice provided by your own physician or other medical problem. You should not use the information contained in the product for diagnosis or treatment of health problem or prescription of medication by yourself.









If you have or suspect that you have a medical problem, consult with your physician promptly.









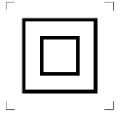

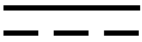

Defective unit or accessories must be packed in the replacement cartons to be shipped off from you to our company.

Shipping and insurance costs for return of defective unit must be prepaid by the users.

5. SAFETY SYMBOLS AND INFORMATION

The International Electro-technical Commission (IEC) has established a set of symbols for medical electrical equipment which classify a connection or warning of any potential hazard. The classifications and symbols are shown below. Save these instructions for your safety.

	<p>Degree of protection against electric shock: TYPE BF</p>
	<p>Please observe operating instructions</p>
	<p>General warning sign</p>
	<p>General prohibition sign</p>
	<p>General mandatory action sign</p>
	<p>Caution</p>
	<p>Waste Electrical and Electronic Equipment (WEEE) The device could be sent back to the manufacturer for recycling or proper disposal after their useful lives. Alternatively the device shall be disposed in accordance with national laws after their useful lives.</p>
	<p>"ON / OFF" key : Turn the power ON / OFF</p>
	<p>Class II equipment</p>

	<p>This symbol is used inside system.</p> <p>Identifies the point where the safety ground of the system is fastened to the chassis.</p>
	<p>Do not open. This is for factory only.</p>
	<p>Alternating current</p>
	<p>Direct current</p>
	<p>Date of manufacture</p>
	<p>Manufacturer</p>
	<p>Non-ionizing radiation</p>
	<p>CE mark</p>
	<p>Serial No.</p>
	<p>Authorized representative in the European community.</p>
	<p>Keep dry</p>
	<p>For indoor use only</p>
	<p>RoHS2</p>

6. Guidance for Electromagnetic compatibility (EMC)

Details about the electromagnetic compatibility (EMC) of the ACCUNIQ BC510 are given below. Before using the ACCUNIQ BC510, be sure to read and understand the following information.

1) Guidance and manufacturer's declaration – electromagnetic emissions

The ACCUNIQ BC510 is intended for use in the electromagnetic environment specified below. The customer or the user of the ACCUNIQ BC510 should assure that it is used in such an environment.

Emissions test	Compliance	Electromagnetic environment – guidance
RF emissions CISPR 11	Group 1	The ACCUNIQ BC510 uses RF energy only for its internal function. Therefore, its RF emissions are very low and are not likely to cause any interference in nearby electronic equipment.
RF emissions CISPR 11	Class B	The ACCUNIQ BC510 is suitable for use in all establishments, including domestic establishments and those directly connected to the public low-voltage power supply network that supplies buildings used for domestic purposes.
Harmonic emissions IEC 61000-3-2	Class A	
Voltage fluctuations/ flicker emissions IEC 61000-3-3	Compliance	

2) Guidance and manufacturer's declaration – electromagnetic immunity

The ACCUNIQ BC510 is intended for use in the electromagnetic environment specified below. The customer or the user of the ACCUNIQ BC510 should assure that it is used in such an environment.

Immunity test	IEC 60601 test level	Compliance level	Electromagnetic environment-guidance
Electrostatic discharge(ESD) IEC 61000-4-2	±6kV: Contact ±8kV: Air	±6kV: Contact ±8kV: Air	Floors should be wood, concrete or ceramic tile. If floors are covered with synthetic material, the relative humidity should be at least 30 %.
Electrical fast transition/burst IEC 61000-4-4	±2kV: Power supply lines ±1kV: Input/output lines	±2kV: Power supply lines ±1kV: Input/output lines	Mains power quality should be that of a typical commercial or hospital environment.
Surge IEC 61000-4-5	±1 kV differential mode ±2 kV common mode	±1 kV differential mode ±2 kV common mode	Mains power quality should be that of a typical commercial or hospital environment.
Voltage drops, dips, and fluctuations of input power supply line IEC 61000-4-11	<5 % <i>UT</i> (>95 % dip in <i>UT</i>) for 0,5 cycle 40 % <i>UT</i> (60 % dip in <i>UT</i>) for 5 cycles 70 % <i>UT</i> (30 % dip in <i>UT</i>) for 25 cycles <5 % <i>UT</i> (>95 % dip in <i>UT</i>) for 5 sec	<5 % <i>UT</i> (>95 % dip in <i>UT</i>) for 0,5 cycle 40 % <i>UT</i> (60 % dip in <i>UT</i>) for 5 cycles 70 % <i>UT</i> (30 % dip in <i>UT</i>) for 25 cycles <5 % <i>UT</i> (>95 % dip in <i>UT</i>) for 5 sec	Mains power quality should be that of a typical commercial or hospital environment. If the user of the ACCUNIQ BC510 requires continued operation during power mains interruptions, it is recommended that the ACCUNIQ BC510 be powered from an uninterruptible power supply or a battery.
Magnetic field	3 A/m	3 A/m	Power frequency magnetic fields

of commercial frequency (50/60Hz) IEC 61000-4-8			should be at levels characteristic of a typical location in a typical commercial or hospital environment.
---	--	--	---

Note	
	<i>U</i> T is the a.c. mains voltage prior to application of the test level.

3) Guidance and manufacturer’s declaration – electromagnetic immunity 2

The ACCUNIQ BC510 is intended for use in the electromagnetic environment specified below. The customer or the user of the ACCUNIQ BC510 should assure that it is used in such an environment.

Immunity test	IEC 60601 test level	Compliance level	Electromagnetic environment-guidance
Conducted RF IEC 61000-4-6	3 Vrms 150 kHz to 80 MHz	3 Vrms	Portable and mobile RF communications equipment should be used no closer to any part of the ACCUNIQ BC510, including cables, than the recommended separation distance calculated from the equation applicable to the frequency of the transmitter.
Radiated RF IEC 61000-4-3	3 V/m 80 MHz to 2,5 GHz	3 V/m	<p>Recommended separation distance</p> $d = 1.2\sqrt{P}$ $d = 1.2\sqrt{P} \quad 80 \text{ MHz to } 900 \text{ MHz}$ $d = 2.3\sqrt{P} \quad 900 \text{ MHz to } 2,5 \text{ GHz}$ <p>where <i>P</i> is the maximum output power rating of the transmitter in watts (W) according to the transmitter manufacturer and <i>d</i> is the recommended separation distance in meters (m).</p>

			<p>Field strengths from fixed RF transmitters, as determined by an electromagnetic site survey,^a should be less than the compliance level in each frequency range.^b</p> <p>Interference may occur in the vicinity of equipment marked with the following symbol:</p> 
--	--	--	---

Note	<p>1. At 80 MHz and 900 MHz, the higher frequency range applies.</p>
	<p>2 These guidelines may not apply in all situations. Electromagnetic propagation is affected by absorption and reflection from structures, objects and people.</p> <p>^a Field strengths from fixed transmitters, such as base stations for radio (cellular/cordless) telephones and land mobile radios, amateur radio, AM and FM radio broadcast and TV broadcast cannot be predicted theoretically with accuracy. To assess the electromagnetic environment due to fixed RF transmitters, an electromagnetic site survey should be considered. If the measured field strength in the location in which the ACCUNIQ BC510 is used exceeds the applicable RF compliance level above, the ACCUNIQ BC510 should be observed to verify normal operation. If abnormal performance is observed, additional measures may be necessary, such as reorienting or relocating the ACCUNIQ BC510.</p> <p>^b Over the frequency range 150 kHz to 80 MHz, field strengths should be less than 3 V/m.</p>

4) Recommended separation distances between portable and mobile RF communications equipment and the ACCUNIQ BC510

The ACCUNIQ BC510 is intended for use in an electromagnetic environment in which radiated RF disturbances are controlled. The customer or the user of the ACCUNIQ BC510 can help prevent electromagnetic interference by maintaining a minimum distance between portable and mobile RF communications equipment (transmitters) and the ACCUNIQ BC510 as recommended below, according to the maximum output power of the communications equipment.

Rated maximum output power of transmitter W	Separation distance according to frequency of transmitter m		
	150 kHz to 80 MHz $d = 1.2\sqrt{P}$	80 MHz to 900 MHz $d = 1.2\sqrt{P}$	900 MHz to 2,5 GHz $d = 1.2\sqrt{P}$
0.01	0.12	0.12	0.23
0.1	0.38	0.38	0.73
1	1.2	1.2	2.3
10	3.8	3.8	7.3
100	12	12	23

For transmitters rated at a maximum output power not listed above, the recommended separation distance d in meters (m) can be estimated using the equation applicable to the frequency of the transmitter, where P is the maximum output power rating of the transmitter in watts (W) according to the transmitter manufacturer.

Note	<ol style="list-style-type: none"> At 80 MHz and 900 MHz, the separation distance for the higher frequency range applies. These guidelines may not apply in all situations. Electromagnetic propagation is affected by absorption and reflection from structures, objects and people.
	

ABOUT BODY COMPOSITION

1. Body Composition

Human body consists of body fat and lean body. Lean body means non-fat constituents of human body like body water, muscles, mineral, etc.

Body water is divided into intra- and extra-cellular water and the ratio between them is controlled and maintained within a certain range. Body fat is piled beneath the skin and between abdominal organs. Body fat is hydrolyzed to make energy needed to normal physiological function when energy supply through food intake is not sufficient, but excessive fat in the body itself is a kind of disease and causes lifestyle diseases.

Healthy people maintain the balance of body composition in a steady proportion but unhealthy people persons fail to keep this balance. When the balance in body composition is broken, diseases like obesity, malnutrition, osteoporosis, etc. can be caused.

2. Obesity

Various methods can be used to assess obesity but the key factor in obesity assessment is the amount of fat accumulated in the body.

In general, obesity is defined as the state of not only excessive weight compared with height (visible obese) but also excessive body fat compared with weight (invisible or visible obese).

Strictly speaking obesity is the state that body fat occupies considerably high ratio to weight.

3. Necessity of Body Composition Analysis

Body Composition Analysis is a good indicator in finding possible health problems. Body composition analysis enables professionals to find obesity or imbalance in body composition at an early stage and helps subjects keep their body healthy.

4. Waist to hip ratio

Waist to hip ratio (W.H.R.) shows the distribution of fat stored in one's abdomen and hip. It is simple but useful to assess body fat distribution. Body fat is stored in two distinct ways. They are often categorized into and called 'apple' and 'pear' type. Apple type shows bigger girth of waist than hip and pear type has bigger girth of hip than waist. If body fat in abdomen increases more, the risk to cardiovascular diseases, diabetes, etc. becomes higher.

5. Abdominal Fatness

Body fat is divided into subcutaneous fat and visceral fat. Visceral obesity is considered to be a critical risk factor along with Percentage of body fat.

Lipoprotein lipase can be easily activated in visceral fat, and it causes visceral fat to be dissolved easily. Dissolved visceral fat goes into liver through the blood vessel and causes fatty liver or increases lipid in the blood. It also elevates the risk of hyperinsulinemia, hypertension, and cardiovascular disease.

Visceral fat generally occupies 10 ~ 20 % of body fat and visceral obesity is assessed based on the indicators below.

- the cross sectional fat area between L4 ~ L5 is 100 cm² and over
- the visceral fat to subcutaneous fat ratio is 0.4 and over
- the waist to hip ratio (W.H.R.) is over 0.9 (male) / 0.85 (female)
- the circumference of waist is over 102 cm/45 inches (male) _ 88 cm / 35 inches (female)

Visceral fat increases after 30s in men and after Menopause in women. It is more common in men than women and the old than the young. Visceral fat tends to increase with aging. Because the combustion rate per minute of visceral fat is higher than that of subcutaneous fat, visceral fat can be easily reduced by exercise or dietary control in case of abdominal obesity. W.H.R. is the ratio of waist to hip circumference and has relation to one's figure.

6. Segmental Analysis

This device analyzes soft lean mass and mass of body fat of five body parts; trunk, right arm, left arm, right leg, and left leg. This function can be used as an assessment tool to evaluate the result of exercise or rehabilitation treatment.

7. Age Matched of Body

It is the estimated physical age of the subject considering body composition analysis result, gender, and biological age. This is calculated by comparing the optimal body composition based on the gender and biological age of the subject with the actual analyzed body composition. It can be used to evaluate the subject's health and body development.

TERM AND FUNCTION OF EACH PART

1. Basic Package

The main system of ACCUNIQ BC510 consists of as follows.

- ① Main body
- ② User manual
- ③ Adapter
- ④ USB Cable
- ⑤ Data management program
- ⑥ Bolts
- ⑦ 5mm L-wrench
- ⑧ Body Cover

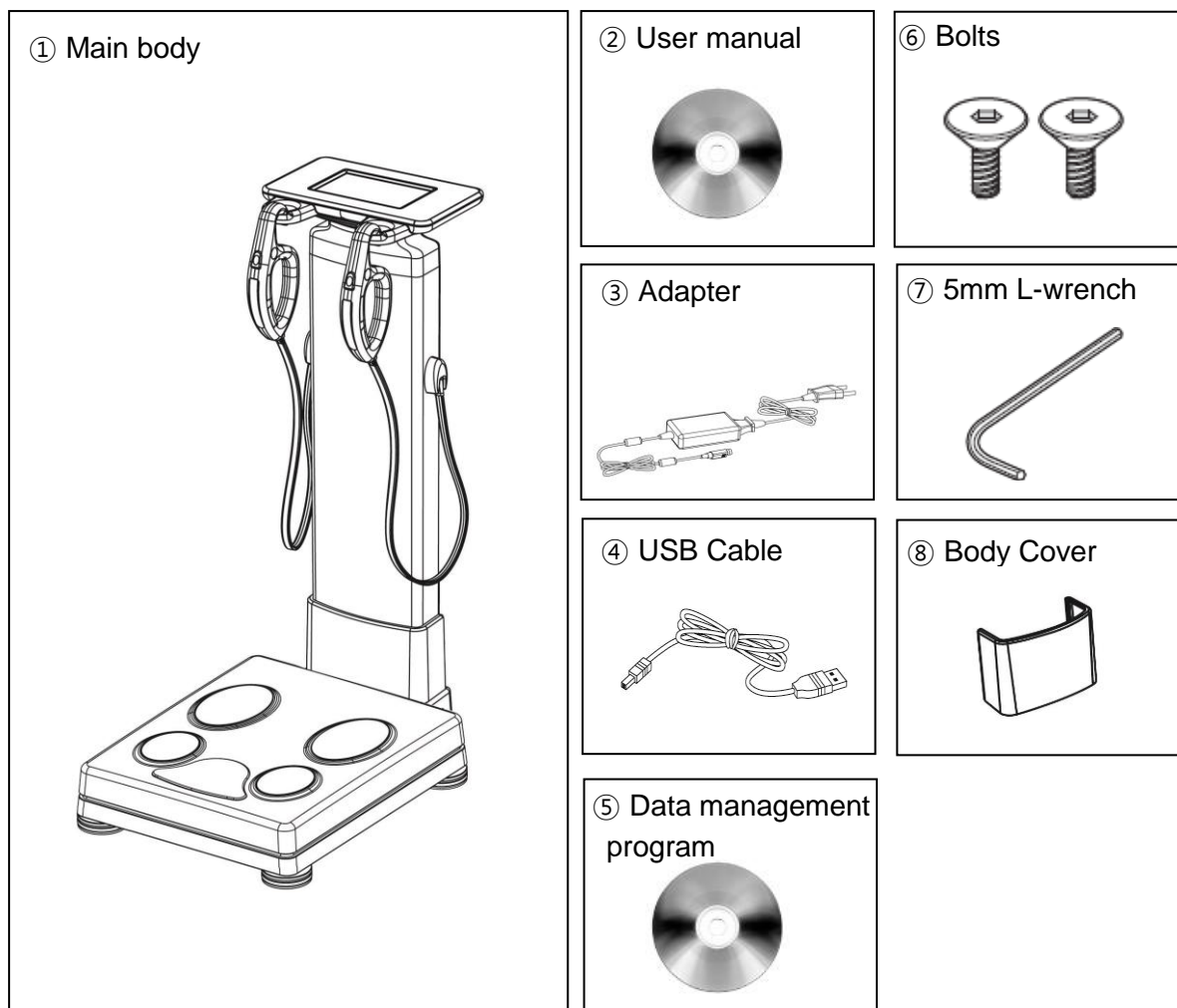

※ Model or specification of accessories can be changed according to market supply and demand.

2. Options

1) Ankle electrodes AE-202

Convenience: can measure with one's socks or stockings on.

- ① Selectivity: can choose either plate electrodes or ankle electrodes.
- ② Hygienic: protects from mold or bacteria
- ③ High accuracy: analyzes more accurately for the person whose sole is corneous

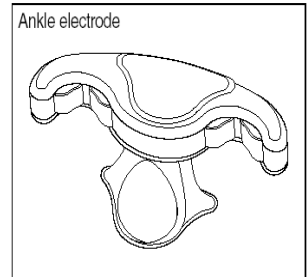

2) Professional health counseling support software

This program helps managing body composition easily and systematically. It shows the core items needed to control body composition. The items include measured body composition, dietary control plan, exercise plan, etc. If the device is connected to blood pressure monitor, it also indicates the measurer's blood pressure.



3) A4 result sheet for segmental parts and children

It shows the segmental results and children growth curve to make users easily understand the condition of 5 body parts and the growing state of children.

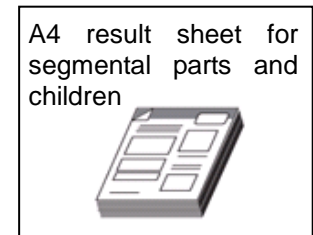

4) Automatic Blood Pressure Monitor

If SELVAS's automatic blood pressure monitor for hospital is connected to this device, the measurer can easily check his/her blood pressure. Especially the patient with hypertension may be able better manage his/her blood pressure through weight control.

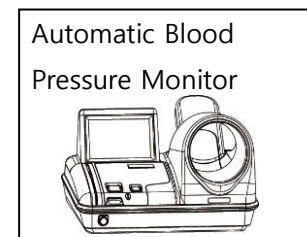

5) Thermal Printer

Thermal printer allows the speedy and convenient printing.

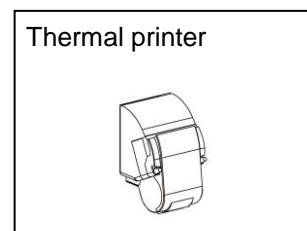

6) Thermal Paper

Measured result is presented in simple and easy way.

Thermal Paper

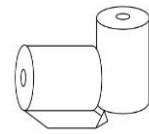

7) Bluetooth

It allows to do wireless communicate with a PC or mobile device.

Bluetooth



8) Height Meter

This is an instrument to measure subject's height more accurately and quickly. It employs standoff determination method using ultrasonic sensor.

Height meter



Note



Measuring height in the morning is average 1~2cm higher than in the evening. Vertebral cartilage is pressed maximum in the evening by gravity and the user's weigh.

※ The accessories can be changed according to market supply and demand.

3. Appearance of the device

1) Front Part

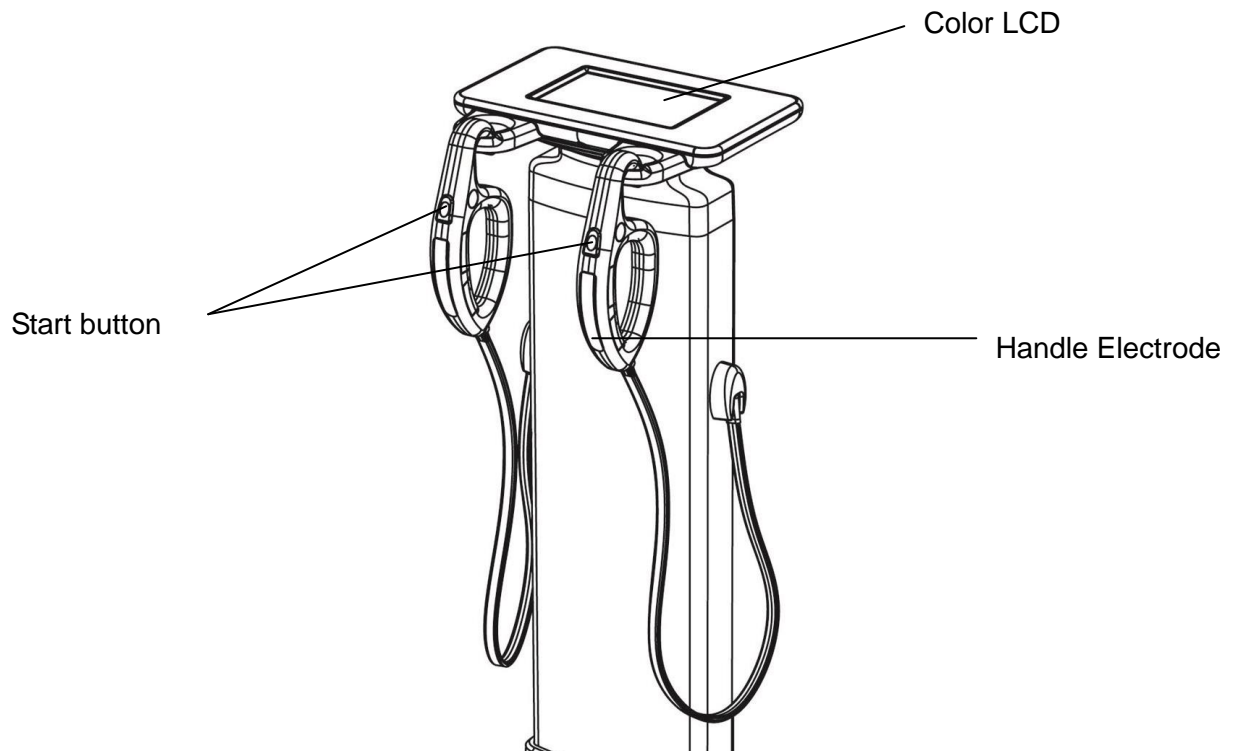

- Color LCD panel as touch screen.
It displays the procedure and results.
- Handle Electrode
Handle Electrode measure the impedance by sending harmless electric current to the body.
Hold them with the hands during measurement.
- Start button
Start button after input of personal data.

2) Rear Part

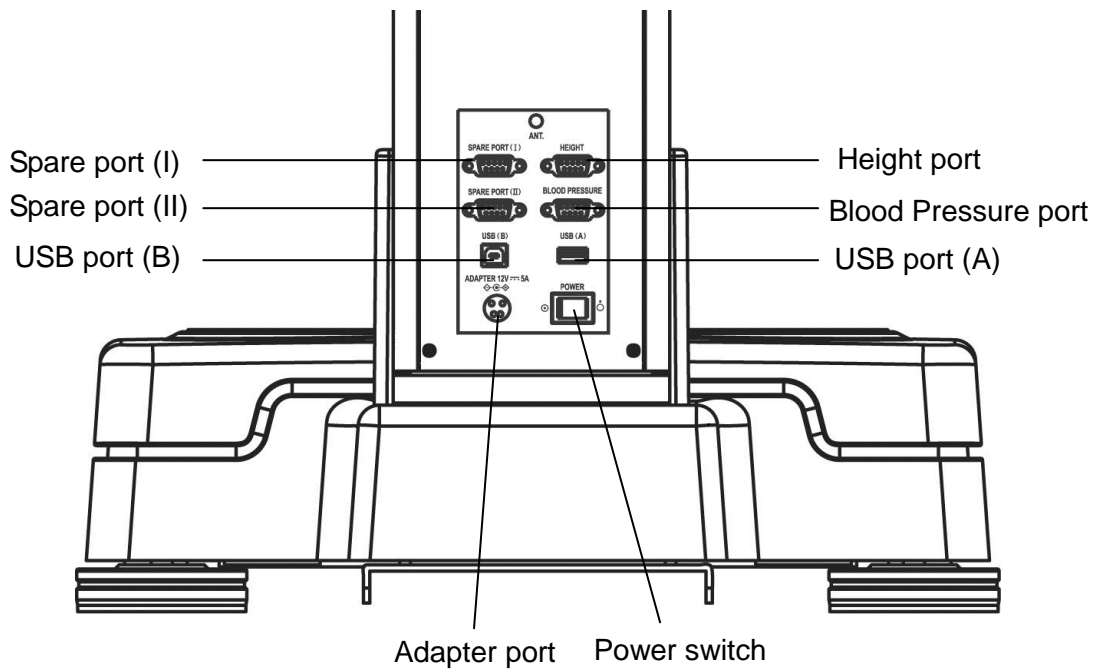

- Spare port(I): Connecting the peripheral devices(Bluetooth, etc.).
- Spare port(II): Connecting the peripheral devices.
- Height port: Connecting the height device. (OPTION)
- Blood pressure port: Connecting blood pressure monitor (OPTION) by SELVAS Healthcare, Inc.
- USB (A) port: Connecting the printer offered with this device.
- USB (B) port: Connecting a computer.
- Adapter port (ADAPTER): Connecting the adapter.
- Power switch (POWER): It can be used to turn on/off the power.

3) Base Part

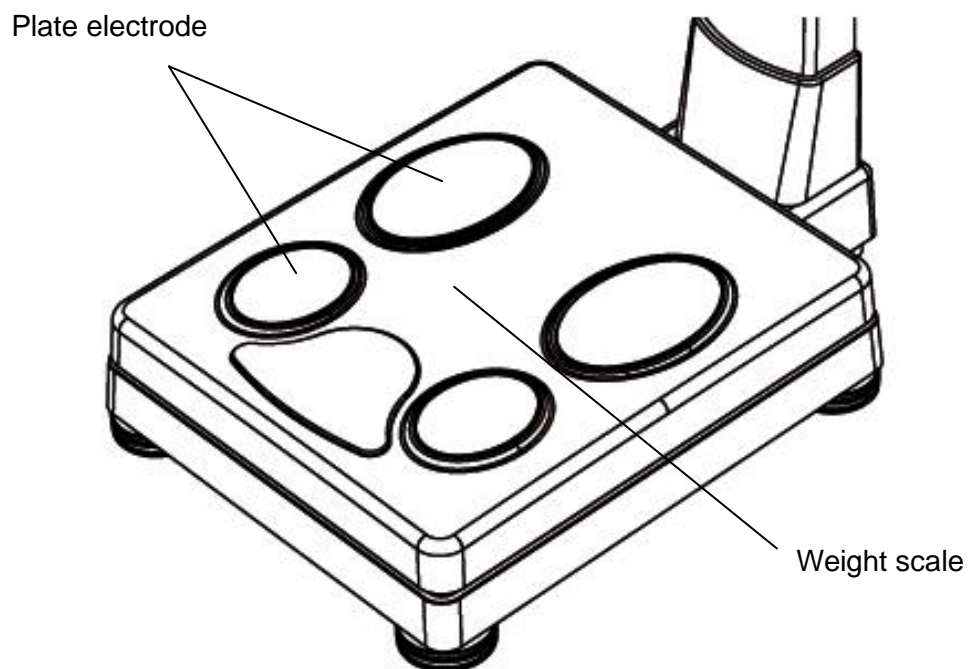

- Weight scale: It consists of four plate electrodes and it measures weight.
- Plate electrode: It measures the impedance. The user should step it in bare feet.

INSTALLATION

1. Power Supply

Connect the power cable to the 'ADAPTER INPUT' placed on the lower back panel of the device. Connect the cable. Turn on the power switch placed next to Power input, then after moment initial screen animation is displayed automatically.

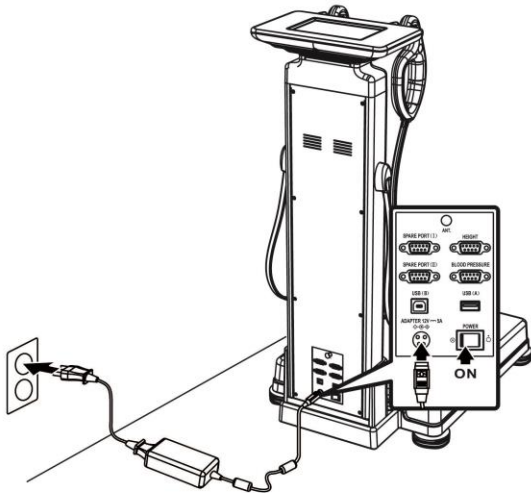

Caution



1. Before connecting a peripheral device to the device, the power should be turned off. Otherwise the devices can be damaged by electric shock or malfunction.
2. When the device and the peripheral devices are connected each other, the order of turning of the devices should start from the device to keep the functions and safe of the device.
3. This device should be only powered through the cable provided by OUR COMPANY.
4. Be careful not to touch the base part of the scale when switching on the device. If at turning on the switch loads any weight on plate electrode, a measuring error might occur with the scale's zero point.

Caution



When connecting the adaptor, place the arrow mark of adaptor connection part up and correctly stick it in the socket on the rear of the main body. Wrong connection could be a hazard.



2. Peripheral Device Installation

1) Connecting Computer

Connect the “USB(B)” port placed on the rear panel of this device to the USB port in computer with USB cable. Or it can be connected through Bluetooth (option).

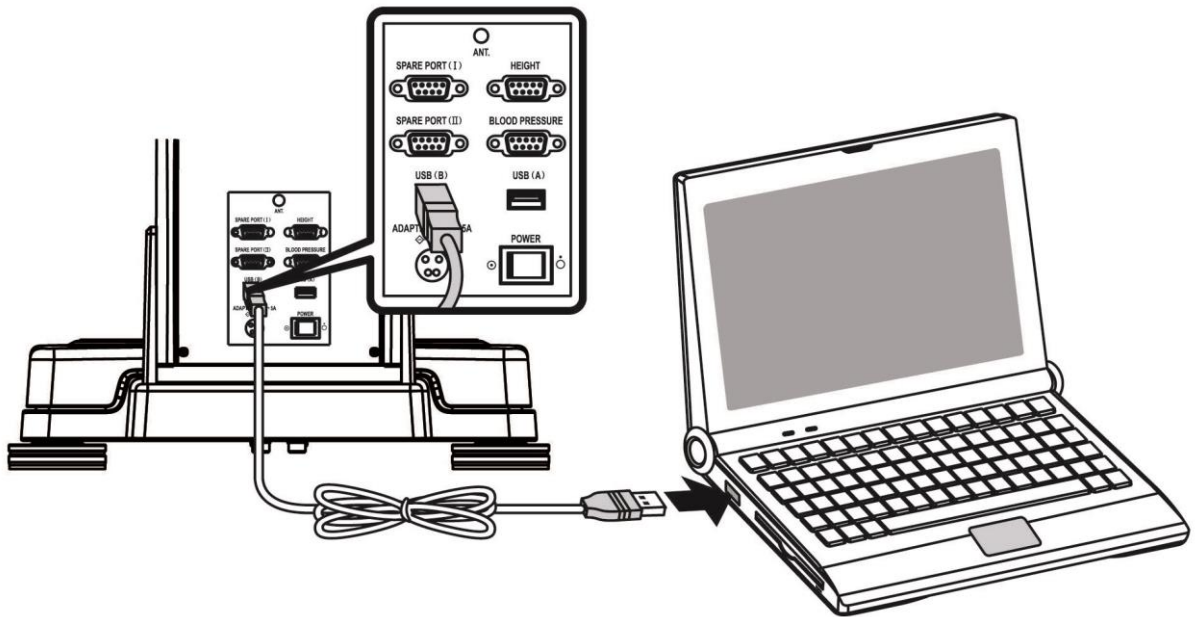

Note



1. If use USB port, the cable should be connected to the computer port.
2. When use computer port, USB driver should be installed at first.
For more information, please refer to the manual CD of software.

Note



1. In order to save, search and retrieve the users' data, the user should connect the analyzer to the computer installed data management software offered free. Printing is done through computer in this case.
2. The professional consulting software optionally provides various printouts. In case of using the software, the pre-printed result sheet is not used.
3. Refer to user's manual for installation of software supplied with CD.

2) Connecting Printer

① Connecting the device and the printer directly

Connect A4 printer offered with this device to the “USB(A)” port placed on the rear panel of this device with USB cable.

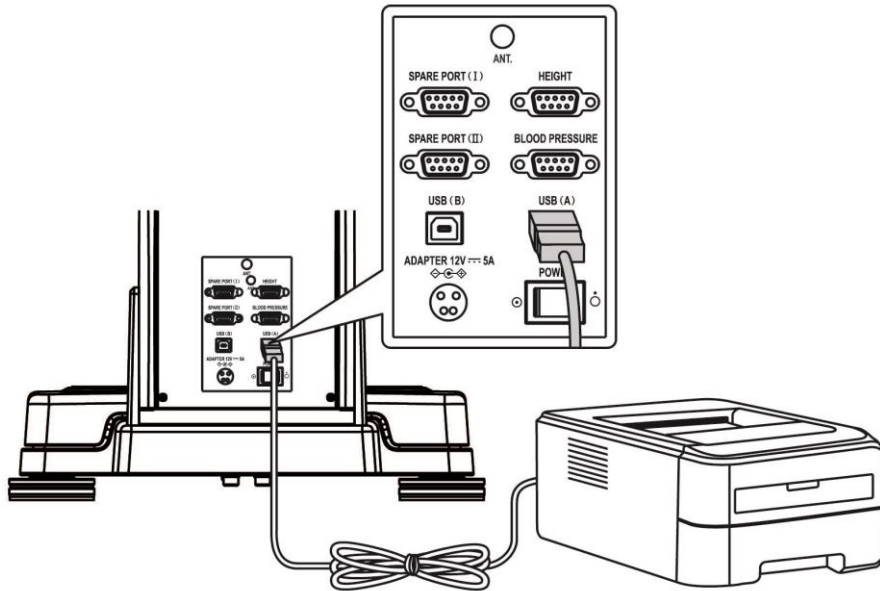

② Connecting the device, computer, and the printer

Connect a computer to the “USB(B)” jack placed on the rear panel of the device with USB cables. Connect the printer to the computer with printer cable. The result sheet can be printed out from the printer.

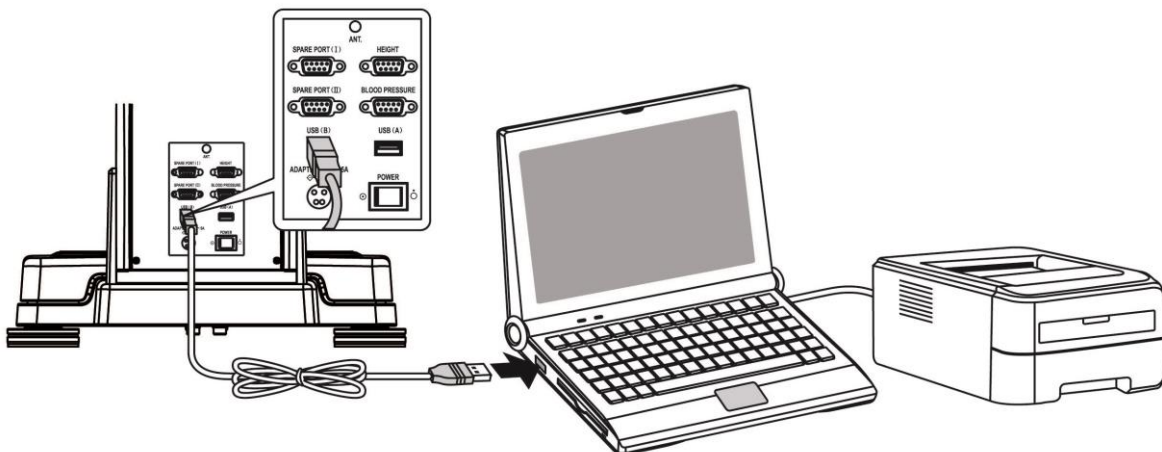

3) Connecting Blood Pressure Monitor

This device can be connected to the automatic blood pressure monitor of our company.

(Option) Connect a blood pressure monitor to “BLOOD PRESSURE (RS-232C)” jack placed on the rear panel of the device with blood pressure monitor cable.

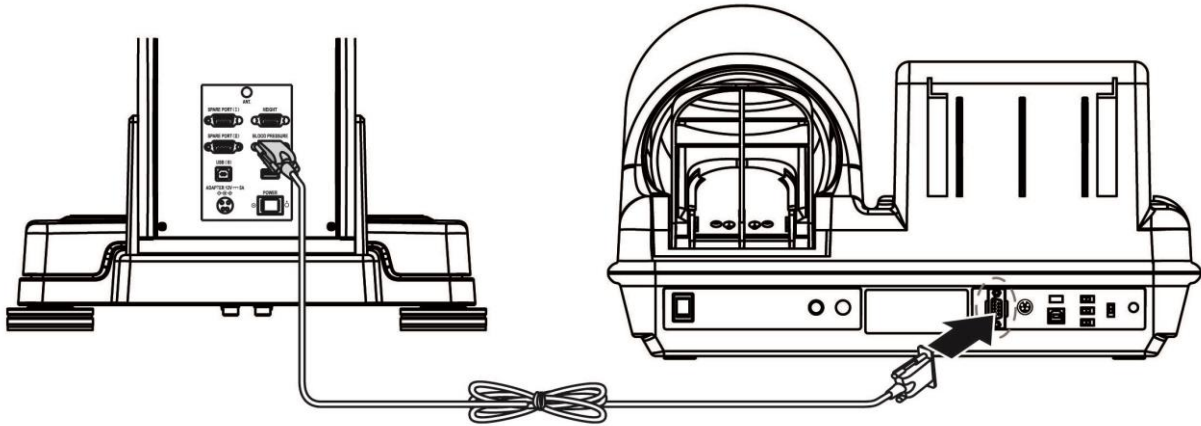

4) Connecting Ultrasonic Height meter

Connect RS 232 cable to the 'HEIGHT ' port placed on the rear panel of the device.

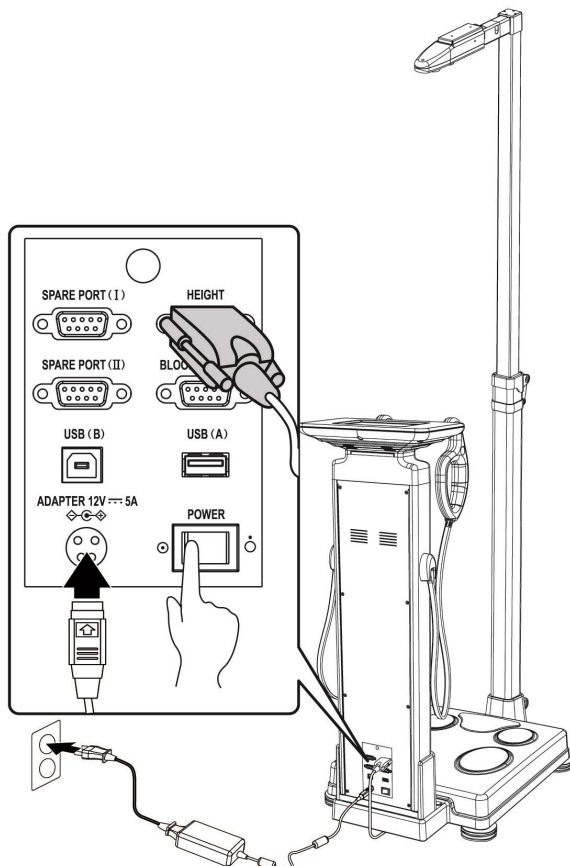

5) Replacing of thermal paper (Option)

Replace thermal paper while the power is on.

- ① Turn the screws counterclockwise and open the cover as shown in the picture.
- ② Insert the thermal paper to the direction as shown in the picture.
- ③ Slightly insert the edge of thermal paper to the printer slot. Thermal paper will be printed out and it automatically cuts out.
- ④ Close the cover and fix the printer cover by turning the screws clockwise.

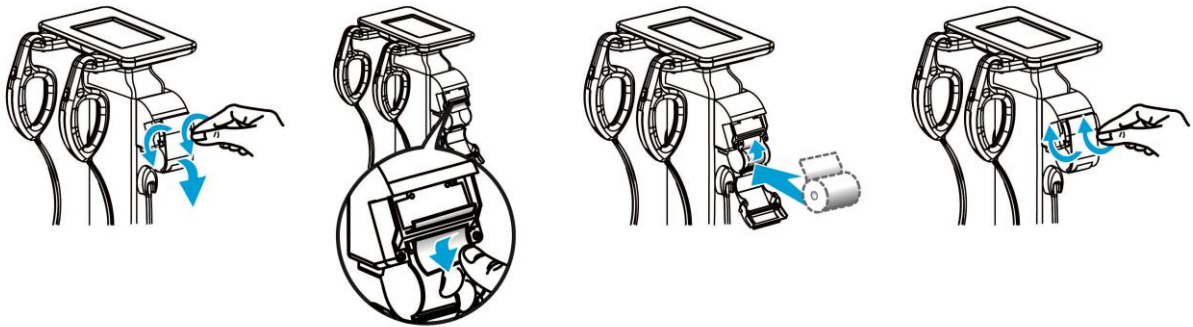

5-1) FEED/CUT functions of thermal printer

• FEED Function

Press upper left corner for 5seconds on the initial screen.

Password window will pop up.

Press '0000' on the password window.

Thermal paper will be printed.

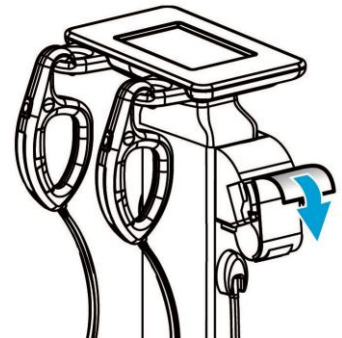

• CUT Function

Press upper left corner for 5seconds on the initial screen.

Password window will pop up.

Press '5555' on the password window.

Paper will be cut.

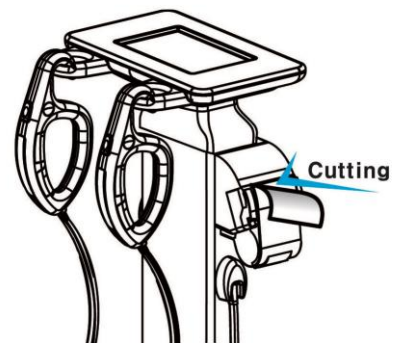

Note



Do not pull thermal paper while printing. Paper will be cut automatically when printing is completed.

SYSTEM SETUP

'SYSTEM SETUP' allows the users to change the setting of operational parameters.

Note



For the purpose of improvement, the contents in SYSTEM SETUP can be changed.

1. Entering SYSTEM SETUP

On the initial display, press '  ' button on LCD for 3~5 second to enter System Set up.

2. Menu in SYSTEM SETUP

Menu items are displayed. The function of each icon is as follows.

1. DATE/TIME
2. VOLUME
3. PRINT
4. PRINT POSITION
5. CLOTHES
6. SCALE OFFSET
7. ABDOMINAL FATNESS
8. DATE TYPE
9. THERMAL PRINT
10. COMMUNICATION
11. ID USAGE
12. CHILD/ADULT/AUTO
13. PLATE/ANKLE
14. SEGMENTAL RESULT SHEET
15. HEIGHT METER
16. DATABASE BACKUP/RESTORE
17. SELECT HEIGHTMETER

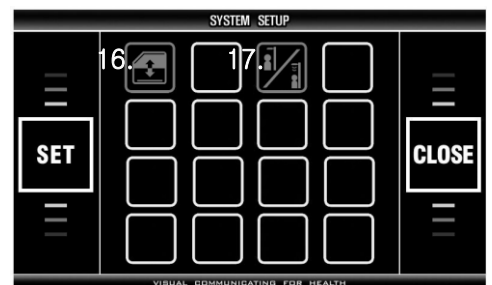

3. Selecting a Menu in SYSTEM SETUP

Select menu according to one's desire, and confirm changes using 「SET」 button.



4. Exiting SYSTEM SETUP

Press 「CLOSE」 button on 'SYSTEM SETUP' phase, then back to initial view of the analyzer.



5. Moving to SYSTEM SETUP

Press 「CLOSE」 button on the menu view, then program is returned to 'SYSTEM SETUP' phase.

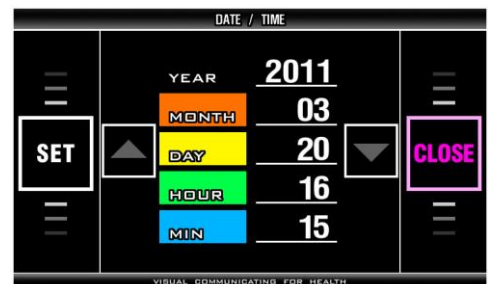

6. Setup

< DATE / TIME >

It sets date and time (year, month, day, hour, and minute).

- Select  (DATE / TIME) on SYSTEM SETUP screen and press SET button on touch pad.
- Pre-set: The date of the device released from the manufacturer's factory.
- Set YEAR by pressing '▼, ▲' on touch pad.
- Press 'MONTH' and set Month.
- Choose DAY, HOUR, MIN and Set correct date and time in the same way.
- Press 'SET' on touch pad to save the change.
- Return to SYSTEM SETUP screen by pressing 'CLOSE' on touch pad.



Note



1. If 'SET' button is pressed before finishing setup of date and time, the date and time inputted at that time is saved and SYSTEM SETUP screen appears. To cancel any changes attempted, press 'CLOSE' then this device saves the previous date and time and SYSTEM SETUP screen appears.
2. When software is used in data management, measured date is automatically saved as the date set in this device. Therefore the date and time set in this device should be checked before use.

< VOLUME >

It adjusts the volume of voice guidance.

- Select  (VOLUME) on SYSTEM SETUP screen with '▼, ▲' button and press 'SET' on touch pad.
- Pre-set: 3
- Range: 0 ~ 9
- Adjust volume with '▼, ▲' button on touch pad.
- Press 'SET' on touch pad to save selected value.
- Return to SYSTEM SETUP screen by pressing 'CLOSE' on touch pad.

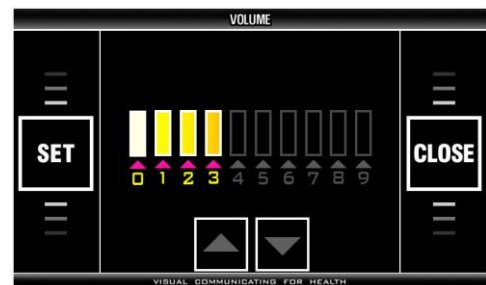

< PRINT >

It selects the printing mode of the A4 printer.

- Select  (PRINT) on SYSTEM SETUP screen and press 'SET' button on touch pad.
- Pre-set: AUTO
- Choose one button on touch pad.
- Press 'SET' button on touch pad to save it.
- Return to SYSTEM SETUP screen by pressing 'CLOSE' button on touch pad.

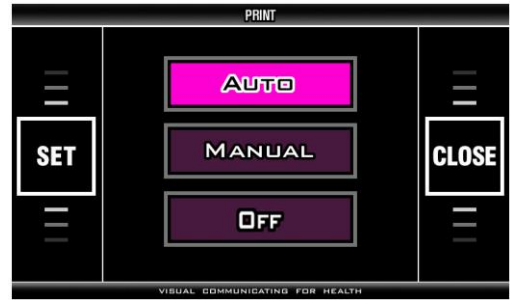

< PRINT POSITION >

It adjusts the printing position in the direction of U-D (up-down) and L-R (left-right) to fit to the pre-formatted result sheet.

- Select  (PRINT POSITION) on SYSTEM SETUP screen and press 'SET' on touch pad.
- Pre-set: 00 for U-D and 00 for L-R
- Range: 99 for U-D and 99 for L-R
- Choose U-D by pressing '▼, ▲' on touch pad. Choose L-R by pressing '►, ◀' on touch pad.
- Pressing ► button moves print position down or right.
- Pressing ◀ button moves print position up or left.
- Every single press moves print position by about 0.2 mm.
- Press 'SET' button on touch pad to save it.
- Return to SYSTEM SETUP screen by pressing 'CLOSE' button on touch pad.

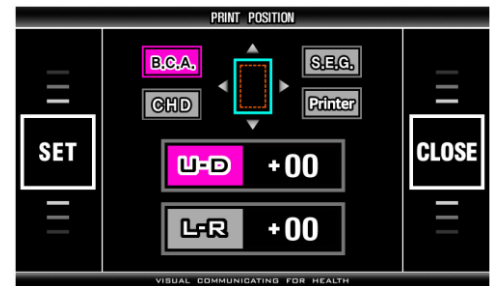

Note



1. L-R (left-right): - is moving to the left and + is moving to the right.
U-D (up-down): - is moving up and + is moving down.
2. The print position needs to be separately set on the result sheet for Body composition analysis and Segmental analysis each.
Press "BCA" and adjust the print position of Body composition analysis result sheet and then press 'SET' button to save the setting.
Press "SEG" and adjust the print position of Segmental analysis result sheet and then press 'SET' button to save the setting.
It is possible to adjust the print position of the result sheet for children if you press the CHD button.
3. Print test
When you press "Print" button, you can print the test page of BCA, SEG or CHD.

< CLOTHES >

It is to subtract the weight of clothes worn by the subjects from measured weight. Calculated value from this setting is used in body composition analysis as subject's weight.

- Select  (CLOTHES) on SYSTEM SETUP screen and press 'SET' on touch pad.
- Pre-set: 0.0 kg
- Range: 0 ~ - 9.9 kg
- Set the value with '▼, ▲' button in touch screen.
- Every single press changes this value by 0.1 kg.
- Press 'SET' on touch pad to save selected value.
- Return to SYSTEM SETUP screen by pressing 'CLOSE' on touch pad.



< SCALE OFFSET >

It compensates measured weight. Calculated value from this setting is used in body composition analysis.

- Select  (SCALE OFFSET) on SYSTEM SETUP screen and press 'SET' on touch pad.
- Pre-set: 0.0 kg
- Range: -9.9 ~ +9.9 kg
- Set the value with '▼, ▲' button in touch screen.
- Every single press changes the value by 0.1 kg.
- Press 'SET' on touch pad to save selected value.
- Return to SYSTEM SETUP screen by pressing 'CLOSE' on touch pad.



< ABDOMINAL FATNESS >

It sets the analysis of abdominal fatness under 18yrs.

- Select  (abdominal fatness) on SYSTEM SETUP screen and press 'SET' on touch pad.
- Pre-set: NO
- Choose YES or NO on touch pad.
- If YES is selected, abdominal analysis is displayed to all age.
- If NO is selected, abdominal analysis is not displayed to the patients below 18 years old.
- Press 'SET' on touch pad to save it.
- Return to SYSTEM SETUP screen by pressing 'CLOSE' button on touch pad.



< DATE TYPE >

This is to set the format of the date.

- Select  (DATE TYPE) on SYSTEM SETUP screen and press 'SET' button on touch pad.
- Pre-set: YY-MM-DD
- Choose the format on touch pad.
- Press 'SET' button on touch pad to save it.
- Return to SYSTEM SETUP screen by pressing 'CLOSE' button on touch pad.

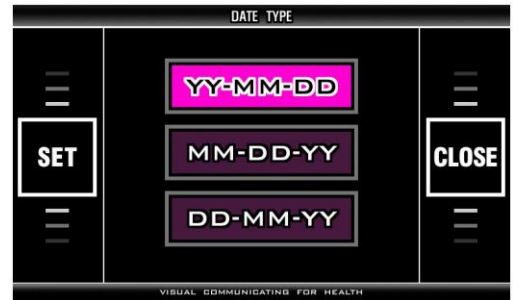

< THERMAL PRINT >

It selects the printing mode of thermal printer.
(Thermal printer is option.)

- Select  (THERMAL PRINT) on SYSTEM SETUP screen and press 'SET' button on touch pad.
- Pre-set: OFF
- Choose 'AUTO' or 'MANUAL' or 'OFF' on touch pad.
- Press 'SET' button on touch pad to save it.
- Return to SYSTEM SETUP screen by pressing 'CLOSE' button on touch pad.



< Communication >

Select the connecting method. 'CABLE' is for USB cable and 'WIRELESS' is for wireless communication.

- Select  (COMMUNICATION) on SYSTEM SETUP screen and press 'SET' button on touch pad.
- Preset: CABLE
- Choose CABLE or WIRELESS on touch pad.
- Press 'SET' button on touch pad to save it.
- Return to SYSTEM SETUP screen by pressing 'CLOSE' button on touch pad.

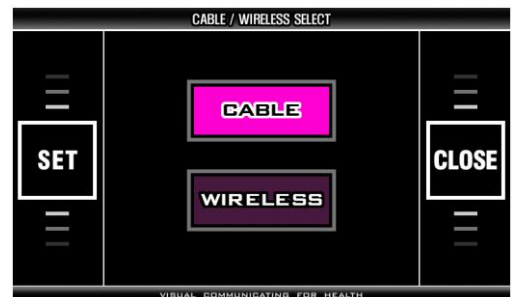

< ID usage >

ID USAGE can be turned off or on.

- Select  (ID usage) on SYSTEM SETUP screen and press 'SET' on touch pad.
- Preset: NO, FLASH MEMORY
- ID USAGE: Choose ID USAGE on touch pad. Choose YES or NO on touch pad.
- SAVE DEVICE: From SAVE DEVICE, select either FLASH MEMORY or USB MEMORY to save the analysis.
- If ID usage is activated, an up to 20-digit ID can be input and saved in FLASH memory or USB memory.
- Press 'SET' button on touch pad to save it.
- Return to SYSTEM SETUP screen by pressing 'CLOSE' button on touch pad.

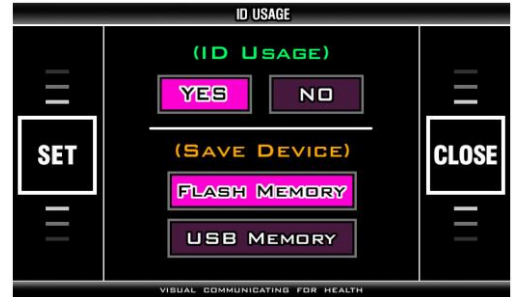

Note



1. If ID function is activated, ID window will pop up at the initial screen. So the user can input ID and save the results. If ID function is not activated, the user should input basic information before the test starts.
2. If FLASH MEMORY is selected, the results are saved in flash memory in the machine itself. If USB MEMORY is selected, the results are saved in portable USB memory stick.

Note



1. When FLASH MEMORY is used,
 - ① Up to 100,000 results can be saved. If the number of saved results exceeds 100,000, the new result will overwrite the oldest result. The results can be deleted and initialized.
 - ② The result sheet can be printed from an A4 printer and a thermal printer.
2. When USB MEMORY is used,
 - ① It is possible to save over 100,000 results. The number of storage differs depending on the capacity of USB MEMORY.
 - ② The result sheet can be printed only from thermal printer.
3. The user should use USB memory (option) supplied only from our factory. Problems caused by USBs which users randomly purchase are not subject to the manufacturer's responsibility.

<CHILD/ADULT/AUTO>

It selects the print format of result sheet.

Choose  and on the initial screen of 'SYSTEM SETUP' to enter the menu.

- Pre-set: AUTO
- Select a print format with the touch pad.
- Press 'SET' button on touch pad to save it.
- Return to SYSTEM SETUP screen by pressing 'CLOSE' button on touch pad.



Note



1. The print format of result sheet

- ① CHILD: No matter what age is set, it prints the result sheet for CHILD. Only the child growth curve is not printed in case of 18 or over 18.
- ② ADULT: No matter what age is set, it prints the result sheet for ADULT. The child growth percentile is presented on the ADULT result sheet in case of under 18.
- ③ AUTO: It automatically selects and prints a CHILD result sheet in case of under 18 and an ADULT result sheet in case of 18 or over 18.

<PLATE/ANKLE>

Select either plate electrode or ankle electrodes.

- Pre-set: Plate electrode
- Enter into the menu view.
- Choose PLATE or ANKLE on touch pad.
- Press SET button to save it and return to main 'SYSTEM SET UP' view with 'CLOSE' button.

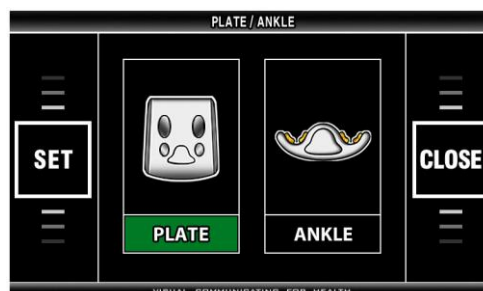

<SEGMENTAL RESULT SHEET >

Segmental result sheet (option) can be selected.

- Pre-set: NO
- Select  to enter the menu.
- Select 'YES' or 'NO'.
- Press 'SET' to save the setting and press 'CLOSE' to return to main 'SYSTEM SETUP' screen.
- In case of choosing 'YES', two result sheets for Body composition analysis and Segmental analysis are printed together and in case of choosing 'NO', only the result sheet for Body composition analysis is printed.

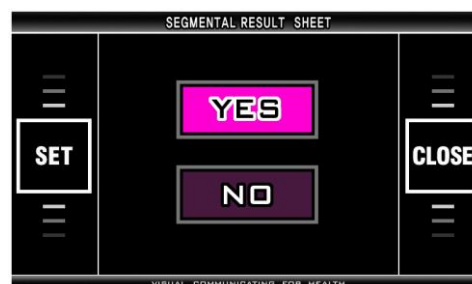

<HEIGHT METER>

Adjust the height meter and select the use of height meter.

- Preset: 000.0cm, OFF
- Adjustable range: ±99.9cm

- Select  (HEIGHT METER) to enter menu screen.

- Adjust the value by pressing '▼, ▲' button on touch pad.

- Press 'YES' or 'NO' on touch pad.

- Press 'SET' button for completing the setup. Press 'CLOSE' button to return to initial screen of 'SYSTEM SETUP'.



Note



1. Height meter is an option.

2. Activate the use of height meter in 'SYSTEM SETUP' when you connect height meter.

<DATABASE BACKUP/RESTORE>

It is for data "Backup" or "Restore", If you want.

- Select  (DATABASE BACKUP/RESTORE) to enter menu screen.

- **BACKUP:** If you want to backup the data stored in the main unit to external memory, connect the external memory to the back and press the "Backup" button. You can see the total number of saved data and the backup progress. Please wait for backup to complete.

- **RESTORE:** If you want to load the data stored in the external memory to the main unit, connect the external memory to the back and press the "Restore" button. You can see the total number of saved data and the restoration progress status. Please wait for the restore to complete.

- When data backup or restore completed, please turn off the power and turn it on again.



<SELECT HEIGHTMETER>

Select either BIKI or Ultrasonic Heightmeter.

- Pre-set: Ultrasonic Heightmeter

- Enter into the menu view.

- Choose BIKI or Ultrasonic Heightmeter on touch pad.

- Press SET button to save it and return to main 'SYSTEM SET UP' view with 'CLOSE' button.



INITIAL SCREEN SETTING

Once turning on the device, you can see the screen same as right picture.

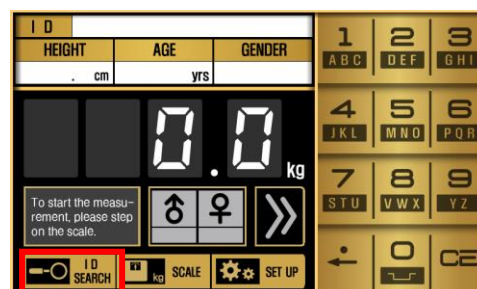

1. ID search

Press  button on the initial screen.

Enter a 20-digit ID with alphabets and numbers mixed and press  button. You can see the results of the ID or print them.

Note



An ID can be searched when 'ID USAGE' is set in "YES".



2. INDEX search

In case of not using ID, INDEX search can be used on the left upper side of the screen.

Press ID on the screen and enter an index number and press  button. Then you can search or see the results and print them.

3. Setting a measurement mode

Users can select one of 'SCALE' and 'BCA' modes.

Long press  button for 3~5 seconds, then the icon will change to  and you can use the device in SCALE mode. In this case, you can only use the device as a scale so it will not start to analyze body composition.

If you long press  button from 3~5 seconds again, the mode will be changed to  (BCA mode).

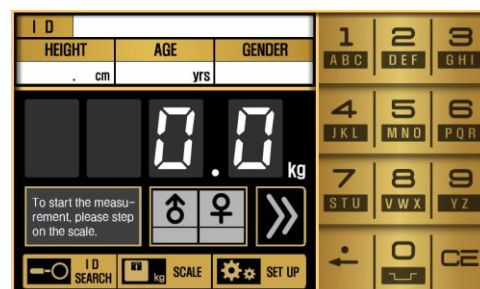

MEASUREMENT AND ANALYSIS

1. Precaution for measurement

The reliability of the results can be assessed by its accuracy. The "Accuracy" of the device is determined by comparing the actual body composition and the results from Body Composition Analyzer. The "Reproducibility" is determined when the device gives the identical results under the same conditions. In order to maintain the accuracy of the results, the following guidelines should be kept.

- ① Water volume increases after a meal. Therefore, measure on an empty stomach.
 - Measure 3 ~ 4 hours after a meal.
 - Avoid beverages containing caffeine or beverages functioning as diuretics 4 hours before measurement.
 - Drink 2 cups of water 2 hours before the measurement.
- ② Before measurement, the subject should be in a stable condition.
 - Measure 3 ~ 4 hours after a bath, a sauna, exercise or activity that sweats a lot.
 - Or measure before these actions.
- ③ Avoid drinking alcohol 24 hours before the measurement
- ④ Wear clothes as light as possible.
- ⑤ Once the subject is on the scale, avoid sudden movement from sitting to standing position. Body fluid goes down to the lower body and affects the results. Thus subjects should be measured after maintaining standing position for 5 minutes.
- ⑥ Clean both the electrodes and measuring body parts.
- ⑦ Changes in room temperature may affect the results. Measurement should be done in a temperature around 20 °C.
- ⑧ Body composition and weight varies even during a day. Therefore, the measurement should be performed at the same time every day. For a person who stands for a long period of time during the day, it is advised to measure in the morning.
- ⑨ Go to bathroom before measurement.
- ⑩ Maintain correct position and posture during the measurement.

In order to keep one's health and the balance of body composition, check the changes of body composition through continuous analysis and compare the results. Make sure that the body composition should be measured under the same physical and environmental conditions. If the condition before the measurement such as volume of a meal, meal time, and activities (exercise, sauna, drinking lots of beverage, urination, etc.) are kept same, the reproducibility of a device is obtained. Therefore, the data can be used to evaluate the change of body composition.

2. Correct position to measure

1) How to touch electrodes

- Make sure that the plate electrodes are clean.
- Take off the socks or stockings then, stand on the plate electrodes.
- Remove sweat or foreign matters on the soles.
- Fairly place the bare feet on the plate electrodes. Make sure that the clothes are not between the soles and the plate electrodes.

When ankle electrode is selected to measure body composition, pull down the socks as show in the picture and make sure the user's ankle is touched on the electrode.

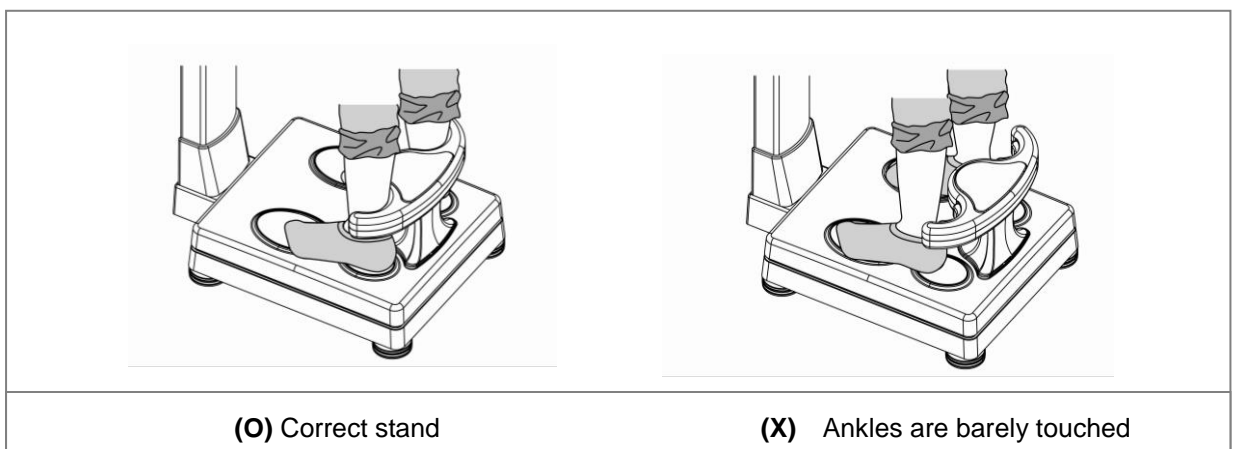
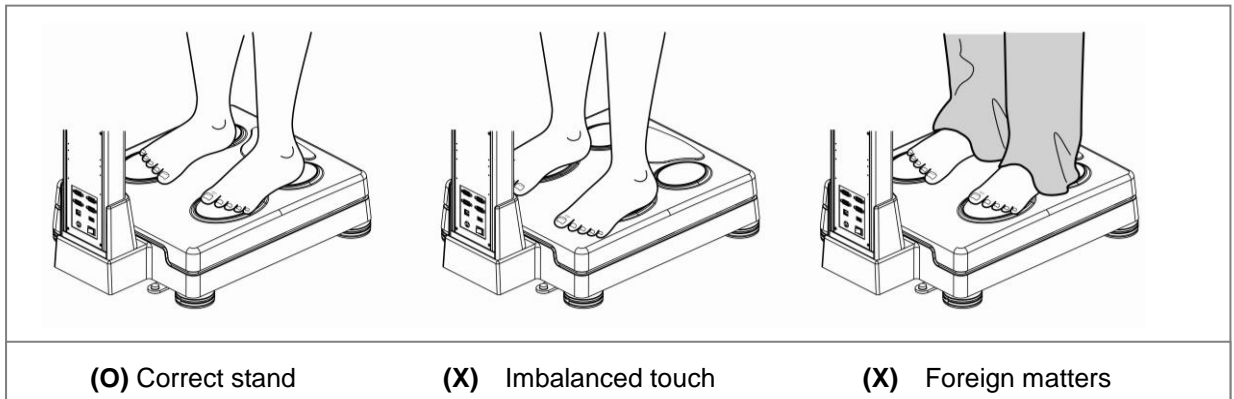

Caution



When using a ankle electrode, be careful not to trip on the electrode before and after a measurement.
Use the ankle electrode after reading and understanding the instructions enough.
Especially the elderly and the infirm have to be more careful of the safety while using the ankle electrode.

2) How to Touch Handle Electrodes

- Grip handle electrodes with fingers and palms.
- 4 electrodes should be touched impartially.
- Stretch both arms and spread them 30° from the body.

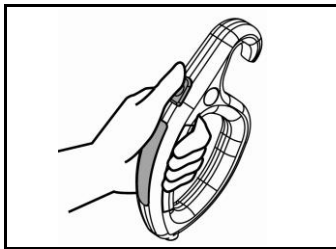

(O) Correct grip

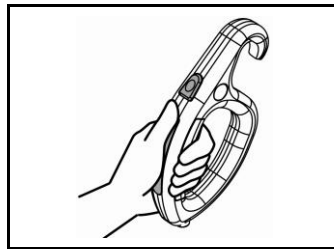

(X) Imbalanced touch

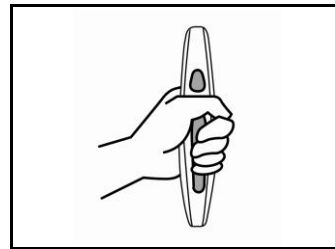

(X) Grip with only palm

Note



If 8 electrodes are not perfectly touched during the measurement, the result is not reliable or the device quits the measurement.

Note



1. When the subject has hands or feet that are too small to cover all electrodes sufficiently for measurement, please pay attention to touch all electrodes fairly. How one touches electrodes will affect the reliability of the analyzed value.
2. During measurement the subject should not be touched by another person or by conductive materials.
3. If 8 electrodes are not perfectly touched during measurement, measuring is quit or the data is not reliable.

3) Measuring Posture

- Step on the scale with bare feet. Stretch both arms and spread them 30° from the body.
- Press start buttons with thumbs for 2 ~ 3 seconds to start the measurement. Once it starts, release the start button and hold the same posture until the measurement is over.
- Do not speak or move the body until the measurement is completed.
- Do not bend or shake the arms until the measurement is completed.
- The measurement will be stopped if all eight electrodes are not fairly touched.

3. Measurement

1) Basic Analysis

① Weight measurement

- When the subject steps on the scale, the screen changes with a chime bell.
- Do not move or speak until the measurement is completed.
- The measured weight is displayed on the screen.



② After the weight measurement, input the personal data.

③ Personal information

Input the following information in a order; ID, height, age and gender. Confirm input data. Press NEXT button.

▪ Input ID

- The following message appears.
"Input your ID, please."
ID can be made up to 20 characters including English, number and a space.



Note



1. If ID is already registered in previous time, input ID and press '🔍'. The data of Height, Gender and age saved in ID automatically appears on the display. The saved data can be changed.
2. When transmit the member information from software to the device, ID USAGES screen will appear. In this case, you can not modify personal information such as height, age and gender at the device. Modify the personal information on the program and transmit the member information to the device again.

▪ Input height

- Press 'HEIGHT' button.
- Input height using the numerical buttons on the touch pad.



▪ Input age

- Press 'AGE' button.
- Input the subject's age using the numerical buttons on the touch pad.



▪ Select gender

- Press 'GENDER' button.
- Select either MALE or FEMALE on touch pad.
- Press '➤' button on touch pad.



④ Measurement posture 1

After inputting the subject's personal data, the screen changes as shown in the picture.

- Fit feet on plate electrodes accurately.



⑤ Measurement posture 2

The screen changes as shown in the picture.

- Grip electrode handles correctly and press start buttons with thumbs at the same time.
- Impedance measurement starts by pressing start buttons.
- Do not move or speak during measurement.



⑥ During the measurement, the following screen appears.

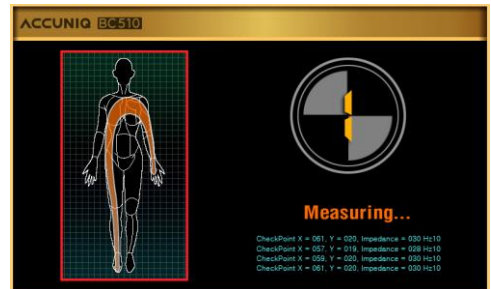

Note



1. Press both start buttons for 2 seconds. Do not move or bend the arms until the measurement is completed. Measuring time is within 1 minute.
2. When the measurement is wrong,
 - Error message appears on the screen.
 - To measure again, hold the handle electrodes and press start buttons with thumbs.
 - If the measurement fails three times in a row, the message appears as below. "The measurement can not complete due to the continuous errors. Step down from the scale for the initialization.
 - Refer to ERROR & REPAIR part for the detail.

⑦ Result screen

- After analysis is completed, the result is displayed on the screen.
- The result is presented with graph and numerical value so it is understood easily.

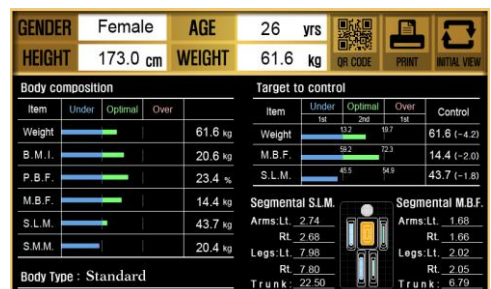

⑧ Scanning QR code

- Press the 'QR code' on the device screen to enlarge the icon and scan the 'QR code' with a mobile device to save the data in the server. After scanning the 'QR code', you can check the measurement data with your mobile device and manage it at will from the server in which it is saved.



Note



1. Scan the QR code with a QR code reader in a smart mobile device.
2. The data saved in the server could be damaged or lost due to a problem with the server.

⑨ Restarting

- Once the result is displayed on the display, it can be printed out in pre-printed result sheet.
- After confirming the analyzed result, press 'Initial view' to restart.
- The device returns to the initial screen after one minute.

2) Analysis using a height meter

An Ultrasonic Height Meter is an optional part. When height meter is connected to the device, it measures the user's height in accurate way.

[Measuring procedure]

- ① Connect the device to ultrasonic Height Meter.
- ② When stepping on the scale, the message "It starts a measurement." on the screen.
- ③ When the measurement completed, it displays the result of weight and height on the LCD.
- ④ With the chime bell, you can start inputting the person data.
- ⑤ The input order is ID, age and gender except height. After it, the measurement process is performed same as the basic order.

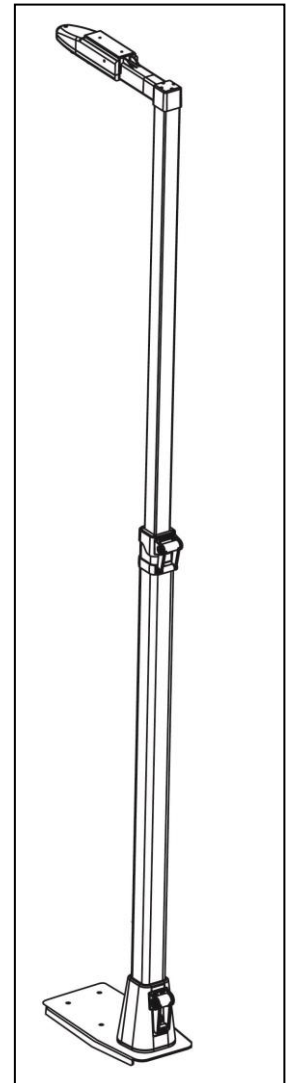

Note



If height meter is not connected, "Height meter is not connected, move to height input mode" message will be appeared.

Check the cable which connects the height meter to the device.

If message above appears while height meter is connected, please ask us or appointed agent.

3) Analysis Using Blood Pressure Monitor

The blood pressure monitor from SELVAS Healthcare, Inc. can be connected to the device as an option.

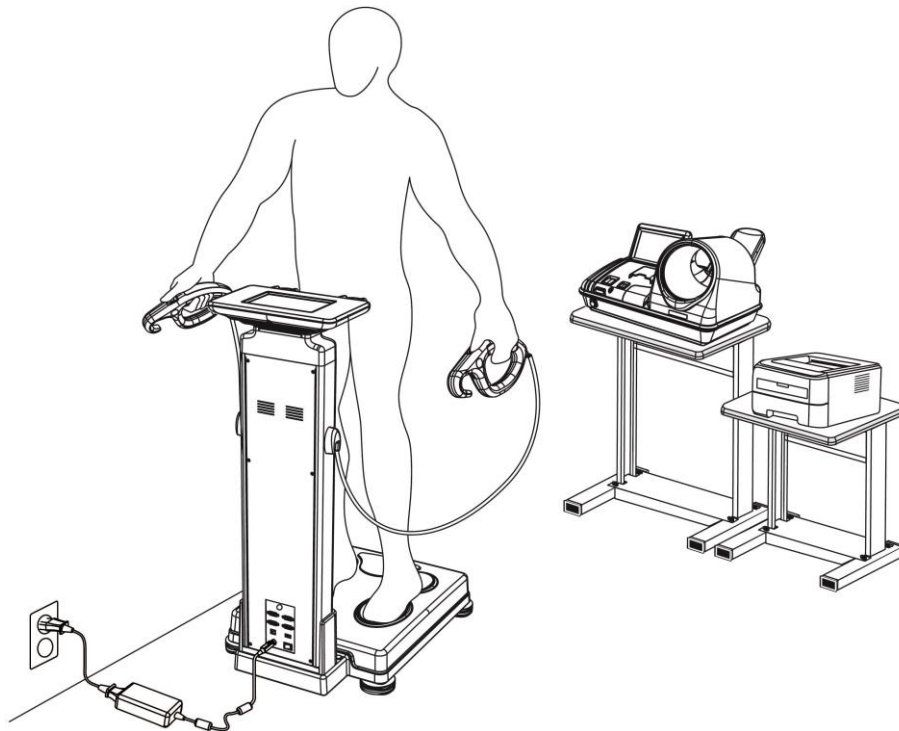

In this way, the blood pressure can be monitored together with weight control. It helps to manage the body fat while checking the blood pressure simultaneously. The measuring procedure is as follows.

- ① Connect a Blood Pressure Monitor to the device.
- ② Connect the device to a computer.
- ③ Turn on the power of BPM and the computer. Turn on the device.
- ④ Input personal data to create a new ID or input an ID which is already registered.
- ⑤ Measure blood pressure first.
- ⑥ Measure body composition.
- ⑦ The results of blood pressure and body composition are immediately displayed on the computer screen after the completion of body composition analysis.
- ⑧ Save the data or print it out.

Note



1. Blood pressure should be measured before body composition analysis. Refer to the user manual of blood pressure monitor for more detail.
2. The result of blood pressure can be printed on the result sheet or reviewed at the program.

STORAGE OF DATA USING USB MEMORY

1. Storage of data

1) On selecting FLASH MEMORY

- ① Insert USB memory stick into USB(A) jack placed on the back side of the device.
- ② The following message appears.
'Do you want to write data to USB memory stick?' on initial screen. Press 'YES' to send to USB memory.
- ③ Transmitting message will be displayed on the screen.
When transmission is completed, the message 'The data writing was completed' will be shown. Press CLOSE to complete the saving process.

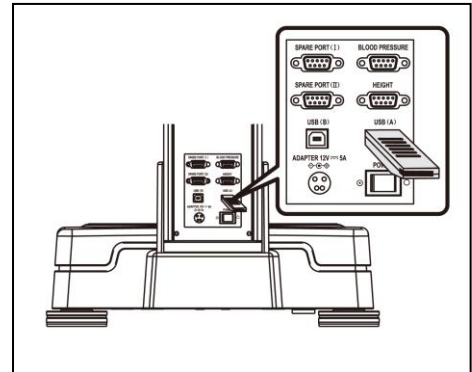

2) On selecting USB MEMORY

When 'USB MEMORY' is selected, measurement data will be stored to USB MEMORY without notification.

Data can only be saved when USB MEMORY is inserted only at the initial screen of device.

If USB MEMORY is not inserted during the measurement, the message "USB MEMORY is not connected" appears. Data will not be stored.

Please insert USB MEMORY and measure again.

If the message above appears even when USB memory stick is inserted, take out the USB MEMORY and insert it again. Please use the USB MEMORY which is provided by SELVAS Healthcare, Inc.

Note



The data can be saved only when 'ID USAGE' function is activated in SYSTEM SETUP.

Note



1. USB memory should be inserted only at the initial screen.
2. When there's no data saved in FLASH MEMORY, the message "No saved data." will appear. Please insert USB memory after measuring body composition.
3. When the saving format is changed from USB MEMORY to FLASH MEMORY, the data saved in USB MEMORY should be transferred to PC.
4. Please refer to program manual for more information.

2. Data Deletion

Press the "0" of 0.0 for 5 seconds on initial screen. Password windows will appear. Press '1111' on Password windows.

The following message appears. "Do you want to delete all data?"

If you want to delete the data, press YES to delete, otherwise press NO.

When deleting the data, the message 'All data were deleted' will appear. Press 'Close' to return to initial screen. (Deleted data can not be restored)

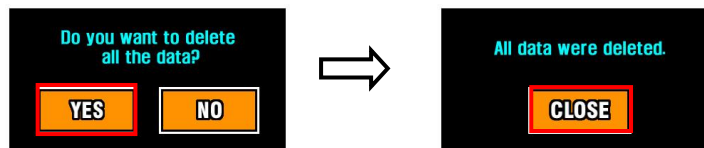

PRINTING

1) Connect printer

Beside the results displayed in LCD, more information can be printed out in the A4 result sheet. The printing procedure using A4 printer is as followings.

- ① Connect the device to A4 printer.
- ② Connect the device to a computer where basic management program is used

2) Result sheet

There are two kinds of result sheet. One is for body composition analysis and the other is for segmental assessment.

- ① For Body composition analysis
Users can see the overall body composition analysis on it.
Body water, Protein, Mineral, Body fat, Soft lean mass and etc.
- ② For Segmental assessment (option)
Users can see the segmental assessments of left arm, right arm, left leg, right leg and trunk.
Segmental E.C.W./T.B.W., Segmental S.L.M., Segmental M.B.F. and etc.
Use it for checking the body balance.

RESULT INTERPRETATION

Here's the explanation and the criteria of the printed results.

1. Personal Data

The subject's ID / name, date, height, weight, age and gender are indicated on the result sheet.

2. Company Logo

The user can input LOGO such as name of hospital, sports center, or obesity clinic, telephone number, address, contact person, etc.

Refer to the manual of software for logo insertion.

3. Body Composition Analysis

The body composition analysis is indicated in the ratio based on the subject's weight.

- ① Weight: It is the sum of total body water, mineral, protein, and body fat in the table.
- ② M.B.F. (Mass of Body Fat): It is calculated by subtracting lean body mass from weight.
- ③ L.B.M. (Lean Body Mass): It is calculated by subtracting mass of body fat from body weight.
Lean body mass consists of fat free mass of body such as muscle, organs, blood and water.
- ④ S.L.M.: (Soft Lean Mass): It composes of body water and protein.
S.M.M.(Skeletal Muscle Mass): Skeletal muscle is also called "voluntary" muscle because one can move this muscle voluntarily unlike visceral muscle. This is the principal form in terms of mass because most of the human body is skeletal muscle. Skeletal muscle enables people to walk and perform other voluntary activities.
- ⑤ Mineral: It composes of bone and electrolyte.
- ⑥ Protein: this is a major element that composes soft lean mass together with body water.
- ⑦ T.B.W. (Total Body Water): It consists of intra-cellular and extra-cellular water. For healthy adults, body water is 45 ~ 65% of body weight even though it varies between persons.
Assessment of Under, Optimal, and Over in the table is assessed by the optimal range based on standard weight of the subject.
- ⑧ I.C.W.(Intra Cellular Water): Water existed in inner cell.
- ⑨ E.C.W.(Extra Cellular Water): Water existed in outer cell membrane like plasma and ISF, etc.
Not only measured data, also evaluation and optimal range based on standard weight are indicated.

4. Obesity Assessment

This assessment help to control the subject's body composition and weight. Body composition analysis result is compared with ideal body composition reflecting age and gender of the subject. The result is displayed in a bar graph. Optimal range of weight and soft lean mass is calculated on the basis of standard weight.

1) Percent Body Fat (P.B.F., %): It is the ratio (%) of the body fat based on the subject's weight.

	low-fat	normal	over-fat	obese	severe obese
Men	less than 15	15 ~ ≤ 20	20 ~ ≤ 25	25 ~ ≤ 30	over 30
Women	less than 20	20 ~ ≤ 30	30 ~ ≤ 35	35 ~ ≤ 40	over 40

2) Body Mass Index (B.M.I., Quetlet's Index: kg/m²): for adults

*EAST ASIA

thin	normal	overweight	obese
< 18.5	18.5 ~ ≤ 23	23 ~ ≤ 25	over 25

* EU and etc.

thin	normal	overweight	obese
< 18.5	18.5 ~ ≤ 25	25 ~ ≤ 30	over 30

5. Abdominal Analysis

Abdominal fatness is divided into subcutaneous type and visceral type. When it comes to body fat, experts say that not only the amount of fat is important but also its distribution. If visceral fat area is over 100 cm² it is classified as "visceral obesity" regardless of P.B.F., W.H.R. or Body weight. Waist-to-hip ratio (W.H.R.) shows the distribution of fat stored in one's abdomen and hip. It is simple but useful in assessing fat distribution. Body fat is stored in two distinct ways. They are often categorized into and called 'apple' and 'pear' type. Apple type shows bigger girth of waist than hip and pear type has bigger girth of hip than waist. If body fat in abdomen increases, the risk to cardiovascular diseases, diabetes, etc. becomes higher.

1) W.H.R. (Waist to Hip Ratio)

W.H.R. is calculated by dividing waist girth by hip girth. When W.H.R. is below 0.9 (male) / 0.85 (female), the risk of visceral obesity is low.

2) Visceral Fat Level: The degree of visceral obesity is displayed in a level.

- Level 1~ 4 corresponds to subcutaneous fat type
- Level 5~ 8 corresponds to balanced type that subcutaneous and visceral fat is balanced.
- Level 9~10 corresponds to borderline type.
If subjects maintain current lifestyle, they will proceed to visceral fat type.
- Level 11~15 corresponds to visceral fat type I .
- Level 16~20 corresponds to visceral fat type II .

3) V.F.A. (Visceral Fat Area): The optimal range is 50 ~ 100 cm² (male), 40 ~ 80 cm² (female).

4) Abdominal circumference: Optimal range is <102cm/40inches (male), <88cm/35inches (female).
Abdominal Circumference is an estimated value in case of measure the navel circumference.

6. Energy Expenditure

1) B.M.R. (Basal Metabolic Rate)

B.M.R. refers to the calories required to maintain human body's basic function such as movement of heart, brain, neural transmission, regulating body temperature and so on. B.M.R. is in proportion to S.L.M. because body fat stores energy while muscle consumes energy. Therefore, even if the weight is same between persons, the person with more muscle has greater B.M.R.

2) T.E.E. (Total Energy Expenditure)

It is the sum of basal metabolic rate and calories needed for daily activity. Generally it is calculated by multiplying B.M.R. by PAL (Physical Activity Level).

7. A.M.B. (Age Matched of Body)

It is the estimated physical age of the subject considering body composition analysis result, gender, and biological age. This is calculated by comparing the optimal body composition based on the gender and biological age of the subject with the actual analyzed body composition. It can be used to evaluate the subject's health and body development.

8. Total score

It is a physical total score which is evaluated considering a subject's body composition analysis result and biological age. On the basis of 100 points, the people in the balanced standard body type get scores around 80. The more the subject is healthy and has soft lean mass, the higher the score is.

9. Impedance

It is the resistance of human body to the electric current that flows through the body. Impedance value can be used in monitoring the function of this device and checking body change of the subject.

10. Body Type

Body type is determined by B.M.I and P.B.F. Body type is classified into 9 types; Low fat Low weight, Low fat Muscular, Athletic, Low weight, Standard, Over Weight Muscular, Thin fat, Over fat, Obese.

11. Segmental Assessment

Soft lean mass and body fat of five body parts (left and right arms, left and right legs, and trunk) are indicated in a diagram

12. Assessment of E.C.W./T.B.W.

Edema is the unbalanced state of intra and extra cellular water. Edema can be increased by salty food, malnutrition, postpartum, exercise, temporary fatigue etc. It is divided into 3 steps; Optimal, Borderline, Over.

13. Body Composition Change

Check change of body fat, soft lean mass and weight for 8 times.

14. Blood Pressure

When the blood pressure monitor supplied from SELVAS Healthcare, Inc. is connected to the device, blood pressure can be measured and the result can be printed out. Systolic blood pressure, diastolic blood pressure, and pulse are printed on result sheet. It helps to recognize hypertension assessment related to obesity.

15. QR code

Scan the QR code with a smart phone to see the result on the website.

STORAGE & MAINTENANCE

- 1) Pay attention to the allowable value of electric current.
- 2) Avoid direct sunlight, humidity, dust, thick oil and salty environment or extreme changes in temperature.
 - ⊗ 3) Do not install or store the device in a place where any chemicals or gas are stored.
 - ⊗ 4) Do not use the device in any unstable, vibrating, or impact-giving area.
- 5) Connect the earth placed on the backside of this device to terminal plate to prevent any electric shock from leaking current or a potential difference.
 - ⊗ 6) Do not put or drop anything on the device and avoid strong impact.
 - ⊗ 7) Do not disassemble or remodel the device.
- 8) If this unit has not been used for a long time, use this after confirming with an expert if all function and appearance are in good condition.
 - ⊗ 9) Do not splash any fluid on this device or insert any foreign substances.
- 10) In case of inserting foreign substances or exposing to particular environment, this device must be examined by an expert before use.
- 11) Use the power cable, plug, and fuse that are offered by our company.

At this time, confirm the covering of cable, the state of plug connection, and other check points.

 - RS 232C cable
 - USB port
 - Adapter
- 12) When pulling out the power cable, turn off the power switch first and then pull the plug out.
- 13) Storage ambient: Temperature -25 ~ 70 °C, Humidity lower than 93 % (non condensing)
- 14) Operation ambient: Temperature 5 ~ 40 °C, Humidity 15 ~ 93 % (non condensing)
 - ⊗ 15) Do not store or use this device under 70 kPa (700 mbar) or over 106 kPa (1060 mbar) of atmospheric pressure.
- 16) Cleaning & Disinfection
 - ① Cleaning: Use a soft gauze cloth with volatile liquid like alcohol (Ethyl or Isopropyl alcohol 70~90%) to clean it.

Clean it every 2~3days. Do not use a wet cloth.
 - ② Disinfection: After measurement, use a soft gauze cloth with volatile liquid like benzene and alcohol. Then, wipe the enclosure with soft lint. Please wipe after every measurement for electrode disinfection.
- 17) Refer to "SAFETY PRECAUTIONS."

Caution



Users must wipe while wearing safety equipment such as gloves when disinfecting electrodes.

Our company does not take responsibility for safety accidents caused by user's carelessness.

ERROR & REPAIR

1. Kinds of Error & Repair

Error	Cause	Repair
Out of range of impedance	<p>When the subject's body impedance deviates from the limit</p> <ul style="list-style-type: none"> - Insufficient touch to electrodes - Impedance is out of range - Range: 100 ~ 950 Ω 	<ul style="list-style-type: none"> • Clean the measuring parts (the electrodes, palms, and soles) and try again. • Measure again with correct posture. • Do not move during measurement. • If the same error is repeated, please contact our company or its local distributor from where this device is purchased.
Out of range of body fat	<p>When the subject's P.B.F. deviates from the limit</p> <ul style="list-style-type: none"> - Incorrect input of personal data - P.B.F. is out of range 	<ul style="list-style-type: none"> • Clean the electrode holders and try again. • After checking that there is neither something with wrong input of personal data (age, gender) nor with measuring error of weight and impedance, try again. • It can't measure if the P.B.F. is out of range. • When the same error occurs even after re-measurement, please contact our company or its local distributor from where the device was purchased.
Out of range of measurement	<p>When the subject's fatness is deviated from the limit</p> <ul style="list-style-type: none"> - Mechanical error 	<ul style="list-style-type: none"> • Input height correctly or if installed height already, measure again. • Confirm to measure weight and try again correctly. • It can't measure if the fatness is out of range. • When the same error is occurred even re-measurement, please contact with our company or its local distributor where is purchased.
Insufficient electrode connection to Ankle	<ul style="list-style-type: none"> • When even one of all 4 electrodes connects with ankle insufficiently 	<ul style="list-style-type: none"> • Connect to ankle all 4 electrodes once more.

<p>Can't input the height</p>	<p>When the subject's height is deviated from the limit - Incorrect input of height</p>	<ul style="list-style-type: none"> • Input height correctly. If the subject's height is out of range, height can't be entered.
<p>Can't measure the weight</p>	<p>When the subject's weight deviates from the limit - Measuring error - Moving during the measurement</p>	<ul style="list-style-type: none"> • Measure the weight again. Don't move or speak during measurement. • It can't measure if the weight is out of range. • When the same error occurs even after re-measurement, please contact our company or its local distributor from where device is purchased.

2. Error & Repair

Error	Cause	Repair
<p>In case that the P.B.F. is too low or too high</p>	<ul style="list-style-type: none"> • Measuring method. Measuring is done under unstable hydration state such as just after physical exercise, a bath, sweating, drinking or overeating. • Move or speak during measurement • Electrode holders or measuring parts are dirty • Faulty in impedance measuring 	<ul style="list-style-type: none"> • Measure again in stable physique. • If there is movement or speaking during measurement, the weight and impedance are not correct. Measure again correctly. • Try to measure again after cleaning the electrode holders with soft gauze. • Try again after cleaning the hands and soles. • Check if foreign materials are between electrodes and measuring parts. • Try again in correct posture and hold the electrodes according to the measuring method.
<p>Machine doesn't Work When 'start' button is pressed</p>	<ul style="list-style-type: none"> • When the electrode holders are disconnected from the main body or contact is faulty. • 'Start' button is defective. 	<ul style="list-style-type: none"> • make sure that the electrode holders are connected to the main body well. • If the same error occurs even after connecting the electrodes well, please contact with company or its local distributor from where device is purchased.

AFTER SERVICE

1. AFTER SERVICE

- ❗ If there is any problem with the unit, please follow the steps below;
- ※ Contact our company's Overseas Service Department immediately.
After gathering the model name, Serial Number, date of purchase and description of the problem, contact our company with information shown below.
 - ※ Try to solve the problem over the phone with the personnel of local service department.
If the problem cannot be solved over the phone, return the unit directly to service department.
 - ※ Our company or local distributor will make available on-request circuit diagrams, component part list, descriptions, calibration or other information which will assist your appropriately qualified technical personnel to repair those parts of the unit which are designated by our company as repairable.

How to contact our company

Write us at:

SELVAS Healthcare, Inc.

155, shinseong-ro, Yuseong-gu, Daejeon, 34109 Republic of Korea

TEL: 82-42-879-3000

FAX: 82-42-864-4462

(You can also contact the following representative or your local distributor)

2. PACKING AND TRANSPORT

Our company wraps this device up with the most suitable method to protect it from any impact or damage during shipping and transporting. This device can be damaged during delivery if it is packed in other ways except the one our company uses. Please handle this device carefully without any impact in packing and delivery.

If this device needs to be transported wrap this device up again and transport it as follows.

- ① Turn off the power.
- ② Turn off the power of the peripheral devices and disconnect all cables.
- ③ Disassemble the device in reverse order of assembly.
- ④ Pack the device with the original packing materials.
- ⑤ Transport it carefully.

SPECIFICATION

Model	ACCUNIQ BC510
Measuring method	Tetra-polar electrode method using 8 touch electrodes.
Frequency Range	5, 50, 250, 550 kHz
Measuring site	Whole body and Segmental measurement (arms, legs, and trunk)
Main items	<p>[Result for Body Composition Analysis] Body Composition Analysis (Weight, LBM, Body fat, SLM, Protein, Mineral, TBW), Muscle/Fat analysis (Weight, SMM, Fat mass), Obesity analysis (BMI and assessment, PBF and assessment, Obesity degree, AC), Abdominal analysis (WHR, VFL, VFA), segmental(Left arm, Right arm, Left leg, Right leg, Trunk) Lean Analysis (Dual Graph), Body water analysis (ICW, ECW, Ratio of ECW), Comprehensive evaluation (Body type, Biological age, BMR, TEE, BCM), Balance assessment (Upper body L/R, Lower body L/R), Control guide (Target weight, Weight control, Muscle control, Fat control), Impedance (Segmental&Frequency), Blood pressure (when connected with blood pressure monitor of our company), QR code</p> <p>[Result for Segmental (optional)] Segmental lean mass and assessment, Segmental fat mass and assessment, Segmental ratio of ECW and assessment, History (Weight, SMM, Fat mass, PBF, BMI, WHR, ECW ratio), Body type (20 types), Abdominal fat type (Subcutaneous type/Visceral type), Impedance (Segmental&Frequency), QR code</p> <p>[Result for Child and Youth (optional)] Body Composition Analysis (Weight, LBM, Body fat, SLM, Protein, Mineral, TBW), Muscle/Fat analysis (Weight, SMM, Fat mass), Obesity analysis (BMI, PBF, WHR), Child growth curve (height, weight), Comprehensive evaluation (Body type, BMR, TEE, BCM, Obesity degree), Balance assessment (Upper body L/R, Lower body L/R), Control guide (Target weight, Weight control, Muscle control, Fat control), Segmental(Left arm, Right arm, Left leg, Right leg, Trunk) Fat mass/Lean mass, Impedance (Segmental&Frequency), QR code</p>
Current	Within 180 μ A \pm 15
Power supply	Input-AC 100~240V~, 50/60Hz, 1.5A Output-DC 12V, 5A, 60VA ADAPTER
Display	7 Inch Wide Color LCD
Input device	Touch pad, PC remote control
Transmitting device	USB port , RS-232C port
Printing device	USB port (the printer assigned by our company), Thermal print (option)
Dimension	447x670x955mm(WxDxH)
Weight	About 21kg (main unit)
Measuring range	100 ~ 950 Ω
Measuring time	Totally within 1 minute
Input height	50 ~ 220 cm / 1ft 7.7in ~ 7ft 2.6in

Measuring weight	10 ~ 250 kg / 22lb ~ 550lb
Applicable age	1 ~ 99 years old
Operation ambient	Ambient temperature range +5 to +40 °C Relative humidity range 15 to 93 % (non condensing)
Storage ambient	Ambient temperature range -25 to +70 °C Relative humidity range lower than 93 % RH

※ For purpose of improvement, specifications and design are subject to change without notice.

WARRANTY

Warranty

Name of product	Body Composition Analyzer		
Name of model	ACCUNIQ BC510		
Serial number			
Period of warranty	Within 2 years from the date of manufacture		
Date of purchase			
Customer	Add.	Name Tel.	
Dealer (market)	Add.	Name Tel.	

Note



- When you receive this warranty, make sure that the name of the dealer and the month, day and year of purchase are all completed.
- This warranty will not be reissued, please keep it in a safe place.

INSTRUCTIONS FOR ASSEMBLY

1. How to install a device

To ensure the operator's security, please work in team of minimum two people during installation, packing and transport.

(1) Components



Body cover

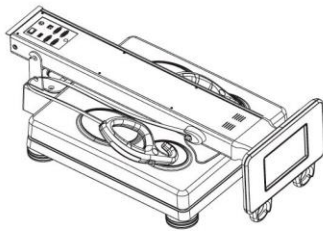

Main unit



M6 bolt

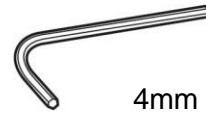

4mm 6angles wrench

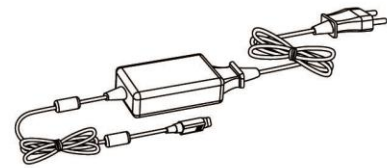

Adapter and Power cable

(2) Unpacking

① "UP" mark should be indicated on the top side of the box when you place the Carton box on a surface.

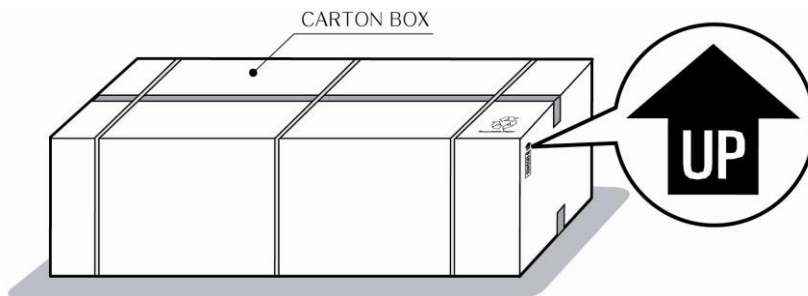

② Remove the strap with a scissor or a knife. Make sure not giving any impact to the device.

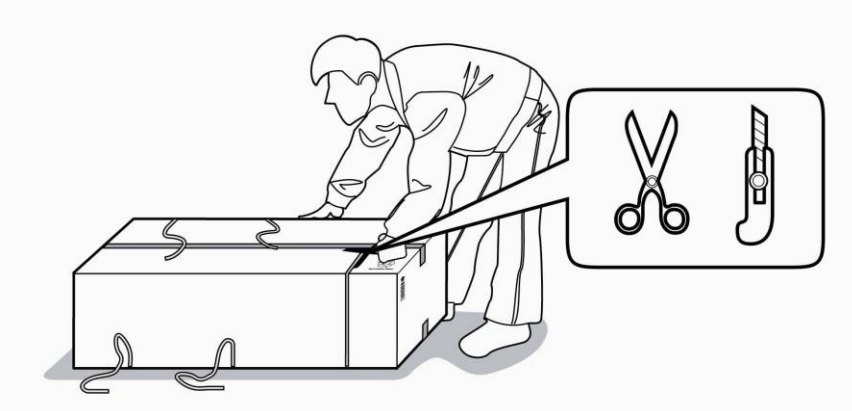

- ③ After opening the Carton Box, fold the box cover outwardly not give contact to the air pack for protecting products. Take out the protection air pack and check its components inside.

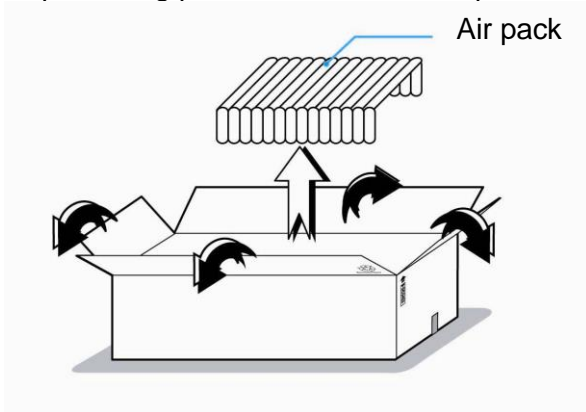

(3) Installation

- ① More than two workers hold the device, and lift it up. Take the device out of the Carton Box.

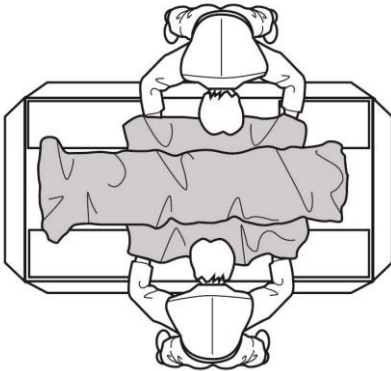

- ② Stand the Body on the flat surface where the slope is less than 10°.

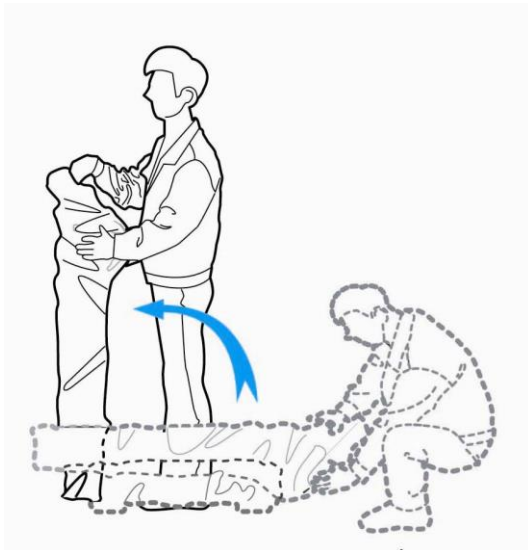

- ③ While one person is holding the column, remove the plastic package from the Body and scale.



- ④ While the one person is holding the column, another inserts two M6 bolts into each side of column and fixes them using 4mm 6angles T-wrench.

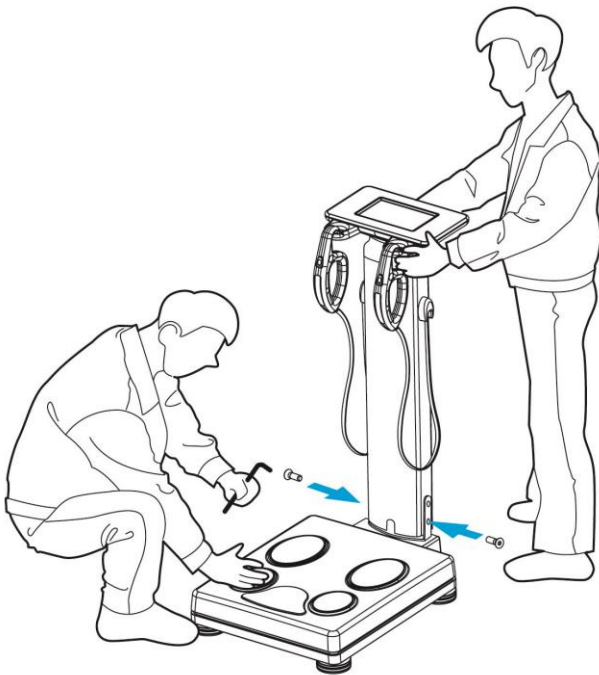

(4) Assembling the body cover

- ① Push the body cover in the arrow direction shown in the picture below and adhere to the scales packing.

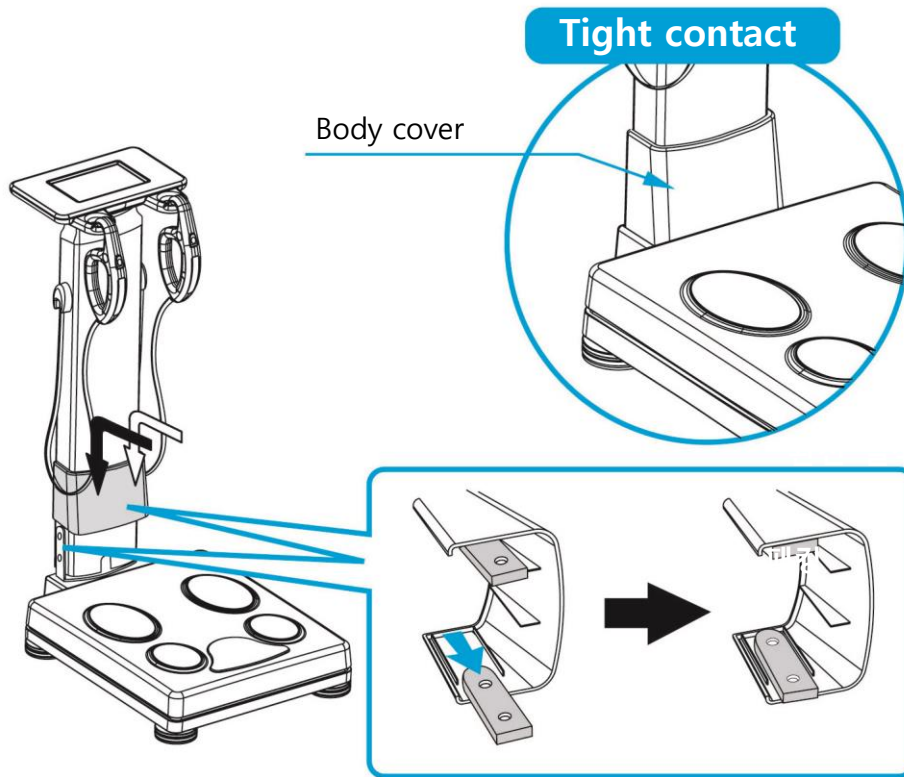

- (5) Adjust the level
Connect the power
Check the level of the device.
If it is not at level, adjust the level using the four wheels.
After adjusting the level, connect the provided adapter and power cable and turn on the device.

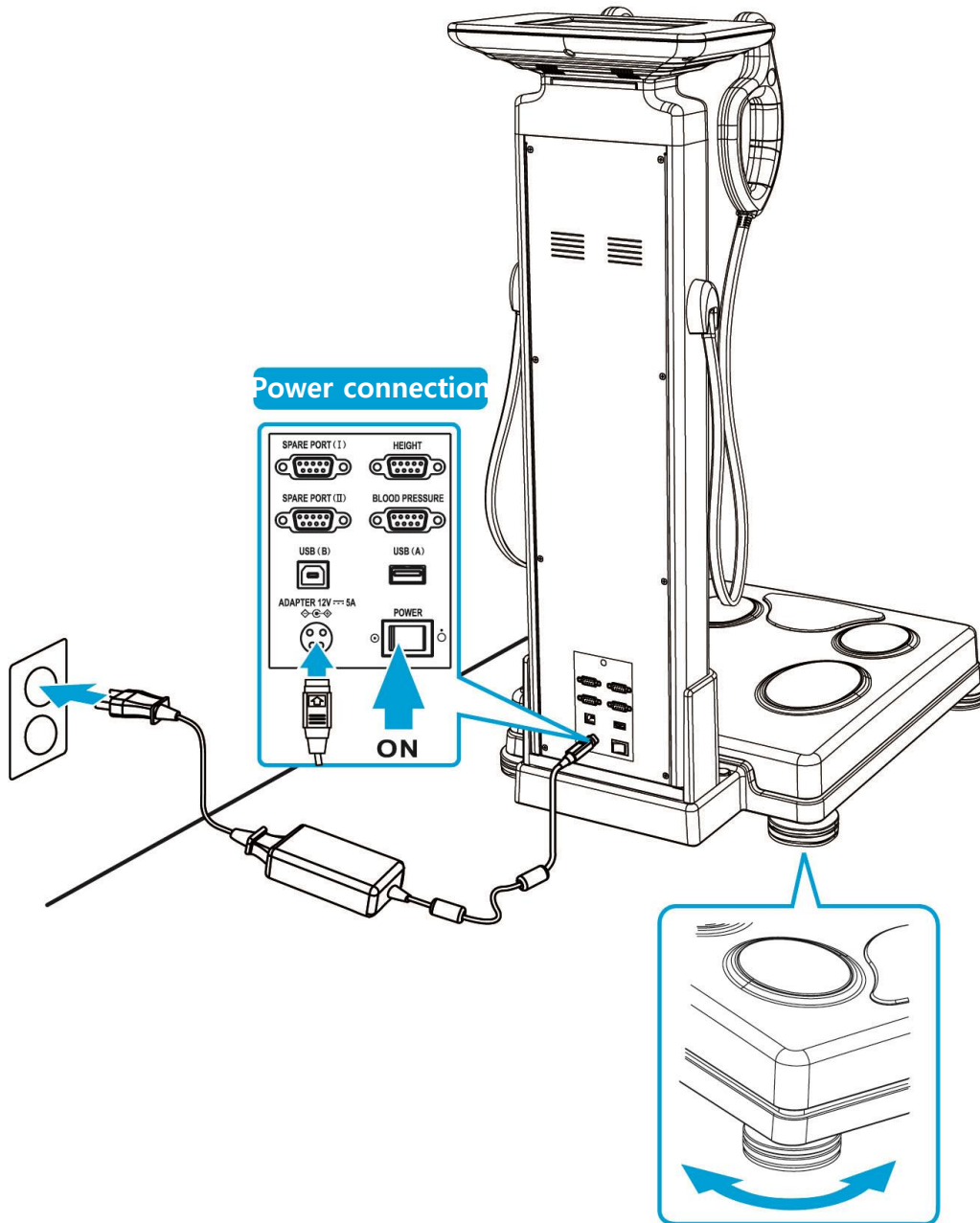

2. Assembling a height meter (option)

Carefully read below and start to assemble the components for a correct installation

(1) Components for installing a height meter

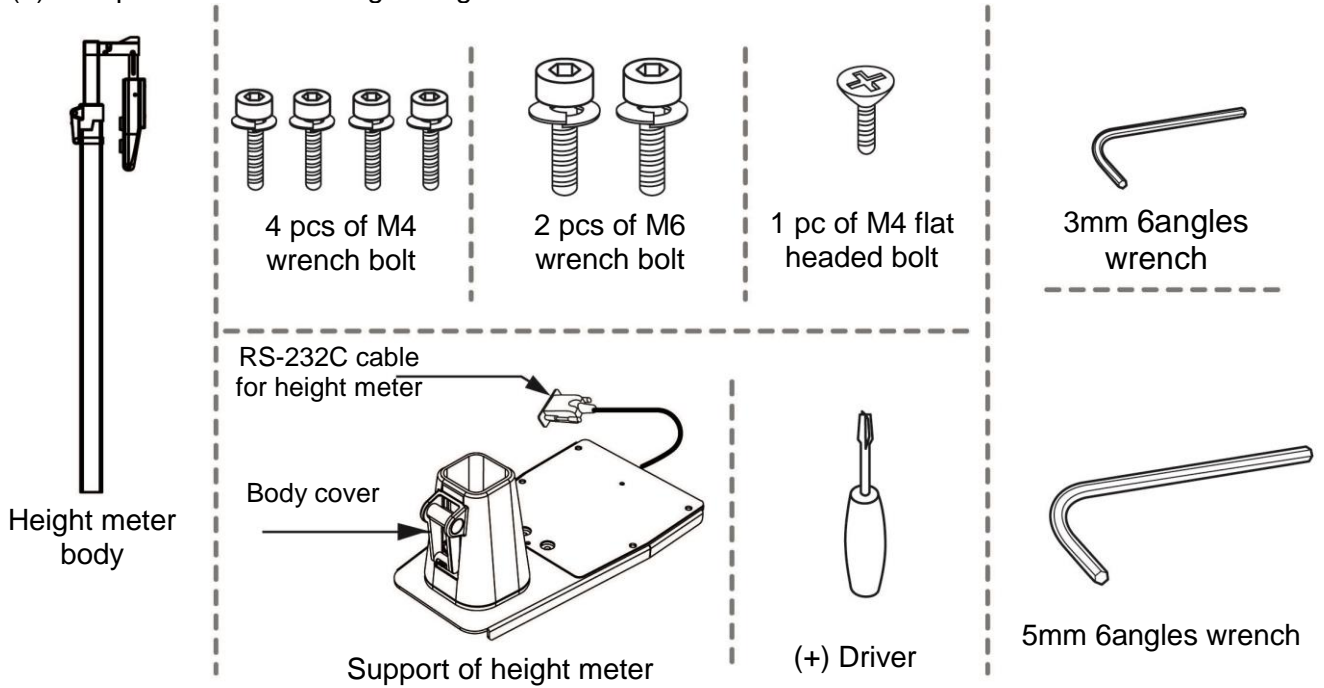

(2) Preparation for installing a height meter

- ① Turn off the power and disconnect the adapter connection socket.

Clean the floor and spread a peach of vinyl or paper on the floor to lay down the height meter. Take away foreign substance and sharp things from the floor. It might cause damage. Open the boxes of the height meter support and the body and check the components.

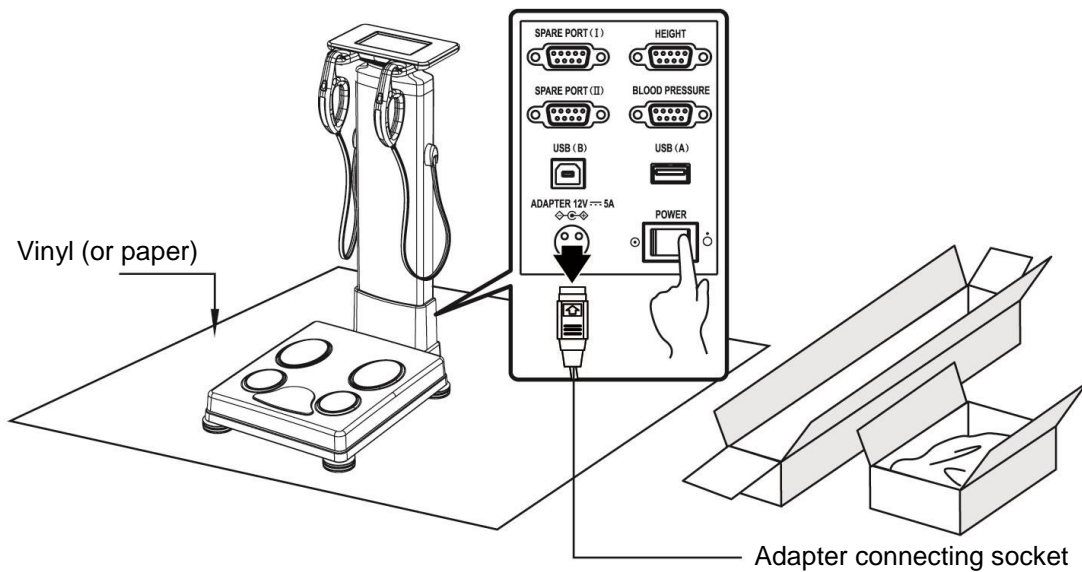

(3) Installing the height meter

- ① Pay attention during the installation and follow the instruction below carefully.

Lay the device aside as shown in the picture.

Put a prop or books to support the column so that LCD would not touch the ground.

Place the handle electrodes at a safe spot.

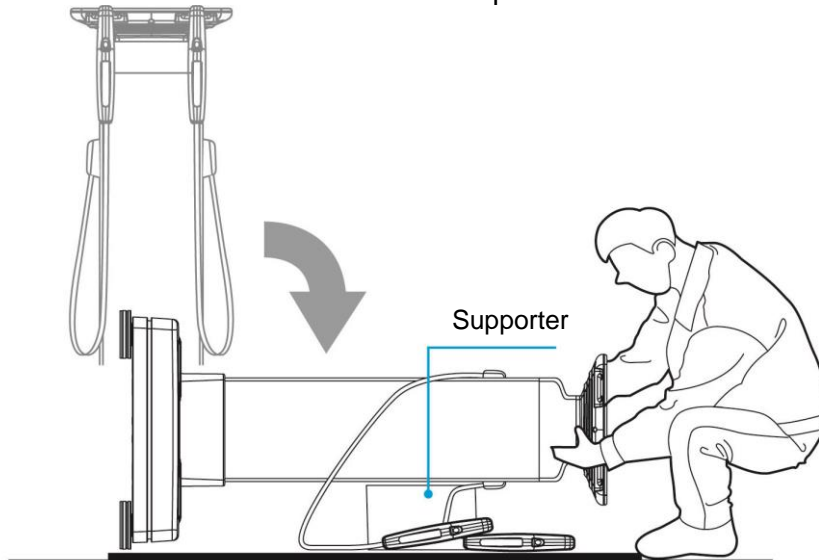

- ② Before the bottom plate of the height meter is attached to the bottom plate of the scale, check the 6 spots where the bolts should be fasten. (1, 2, 3, 4 holes: Use M4 wrench bolts and 3mm wrench tool / A, B holes: Use M6 wrench bolts and 5mm tool)

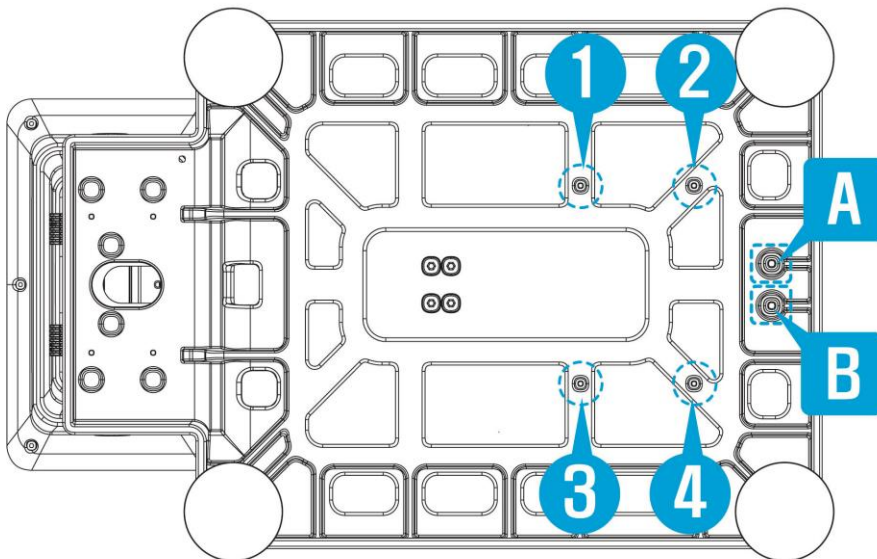

- ③ Fix the bottom plate of the height meter to the bottom plate of the scale. Make sure that 6 holes are matched.
Put M4 wrench bolts and M6 wrench bolts to the appropriate holes and fasten them tightly.
(Use 3mm wrench tool for M4 wrench bolts. / Use 5mm wrench tool for M6 wrench bolts.)

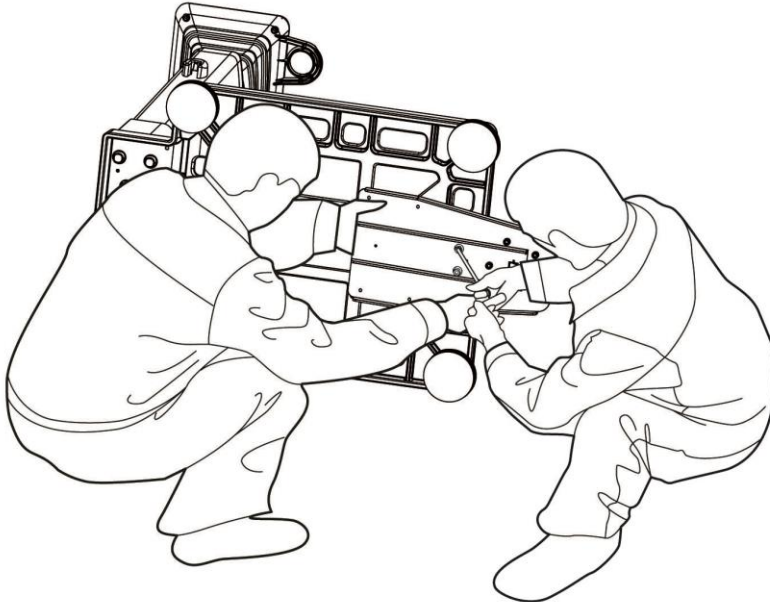

- ④ Recheck if the 6 bolts are put into the right spots as shown in the picture.
(1, 2, 3, 4 holes: Use M4 wrench bolts and 3mm wrench tool / A, B holes: M6 wrench bolts and 5mm wrench tool.)

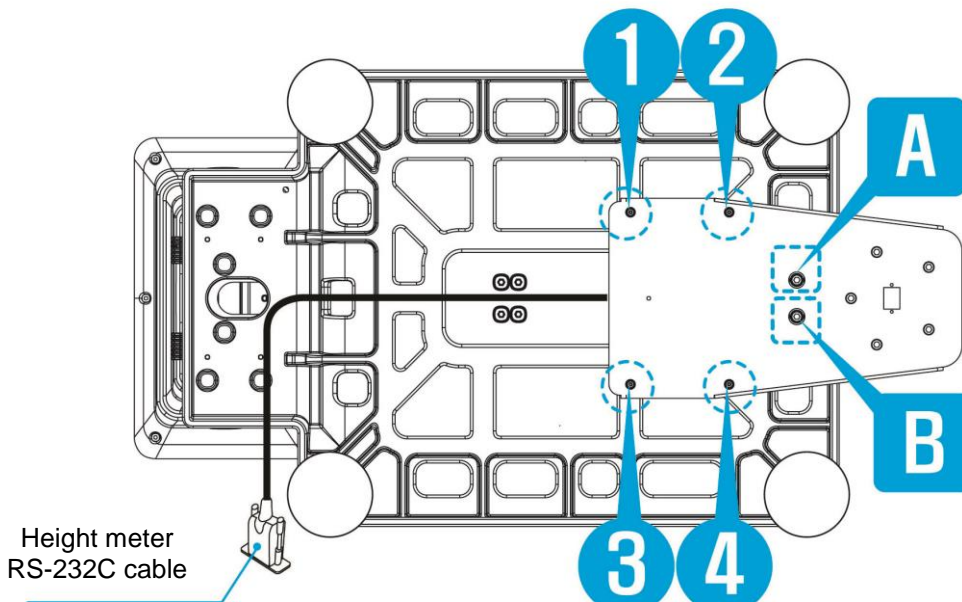

- ⑤ After the bottom plate of the height meter is installed, stand the device on the flat surface. Please do the operation following the instruction carefully. Remove the prop, paper or vinyl on the floor.

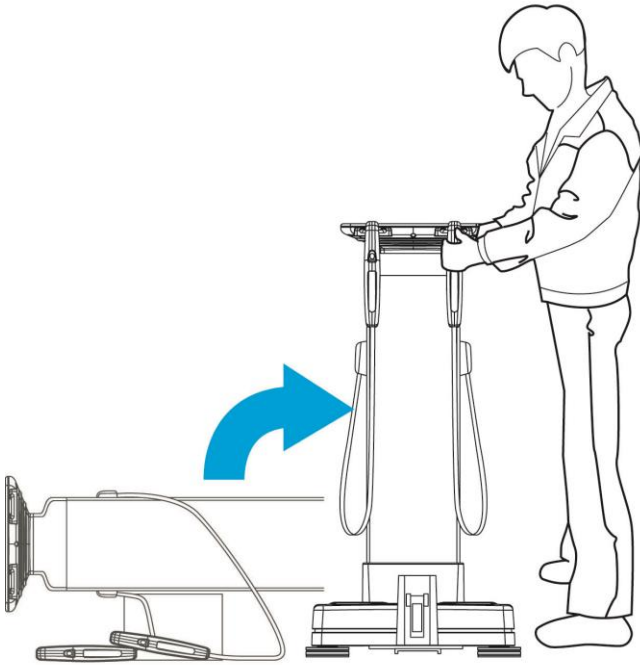

- ⑥ Take the height meter body out of the box and unwrap the body. Push up the head of the height meter to the (A) arrow direction and push it to the (B) arrow direction. Make sure if the holes are matched. Fasten M4 plate head bolts using a (+) driver as shown in the (C) picture.

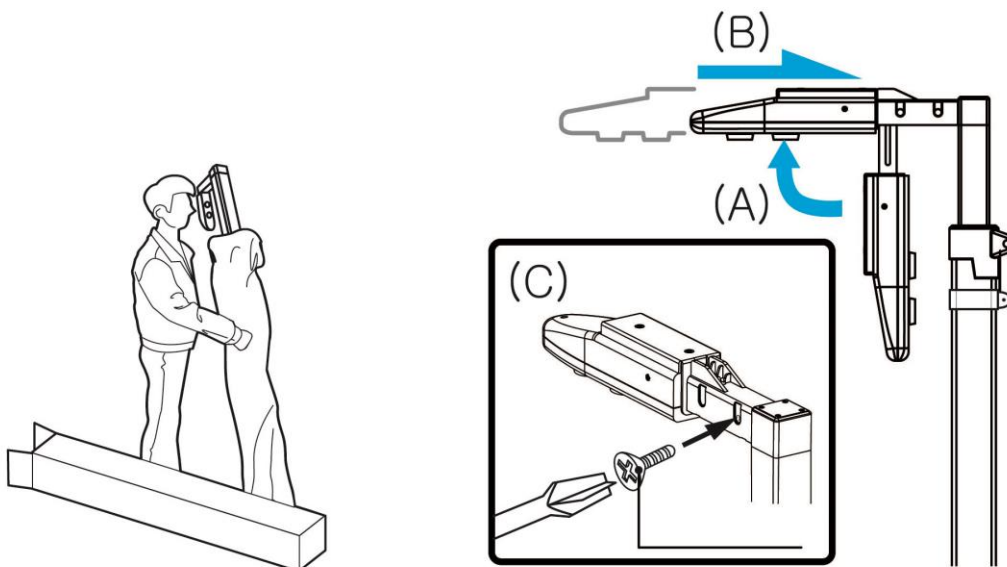

- ⑦ Lift up the fixing lever to the arrow direction as shown in the picture.

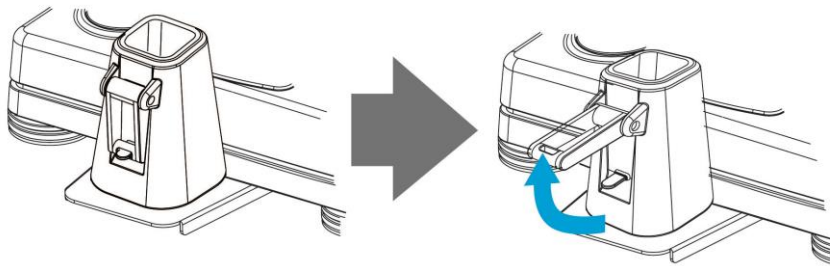

- ⑧ Slightly press the rubber pad located at the inner body cover to make the height meter body put into easily.
Put the height meter body in the body cover. (*Note: RS-232C connector at the bottom of the height meter body should be placed at the connector socket.)

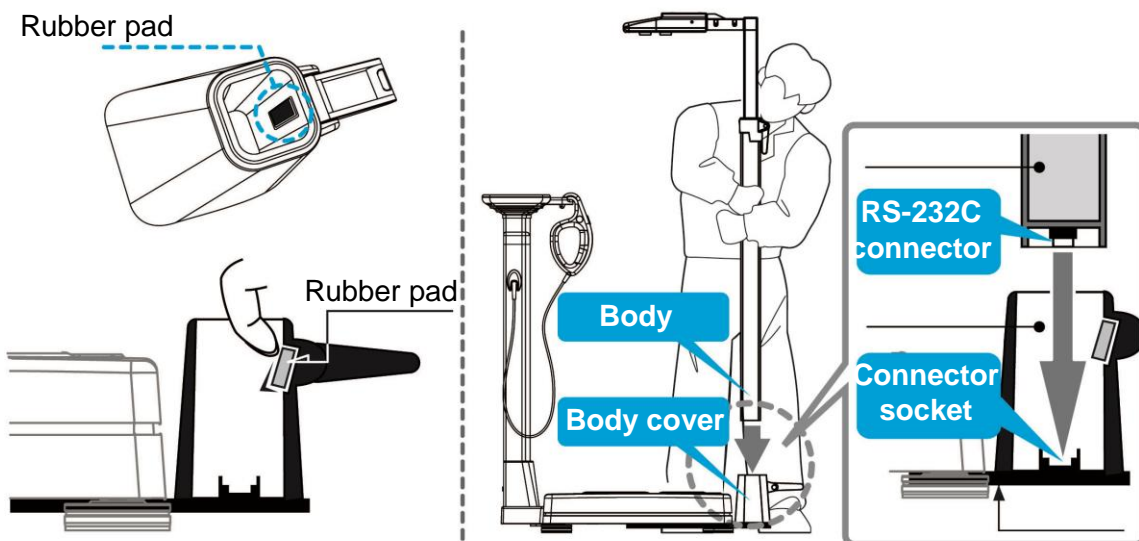

- ⑨ Pull the fixing lever down and fix it as shown in the picture.

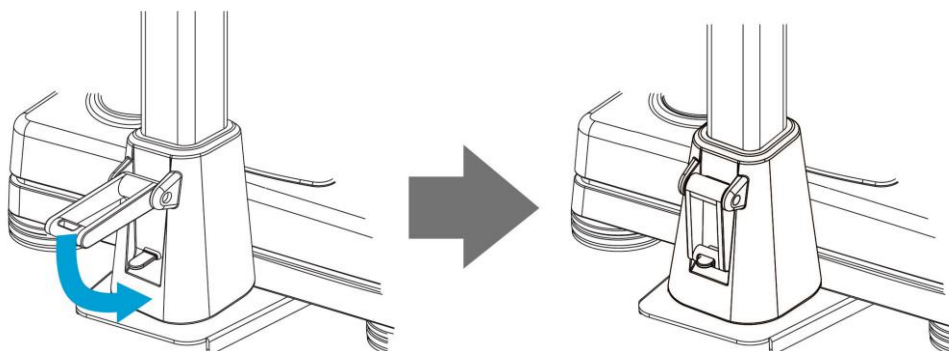

- ⑩ Lift up the fixing lever located at the middle of the height meter body to the arrow. Lift up the inner column to the end and pull down the fixing lever to the arrow and fix it. Also move the fixing rack to the spot where the fixing lever is matched. Fix it as shown in the picture using 2 ea of M4 bolts and a (+) driver.

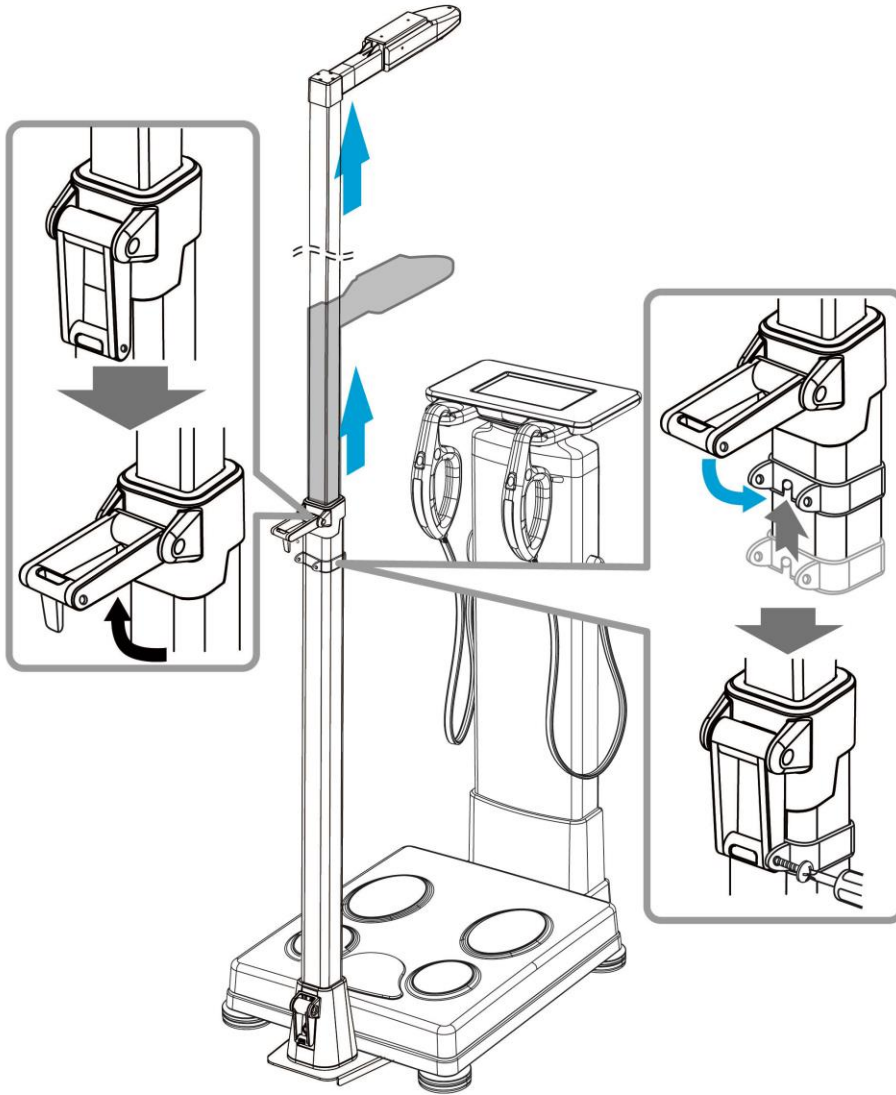

- ⑪ Connect a RS-232C cable to the “HEIGHT” port on the back side of the device.
Connect it to the adapter and turn on the power.

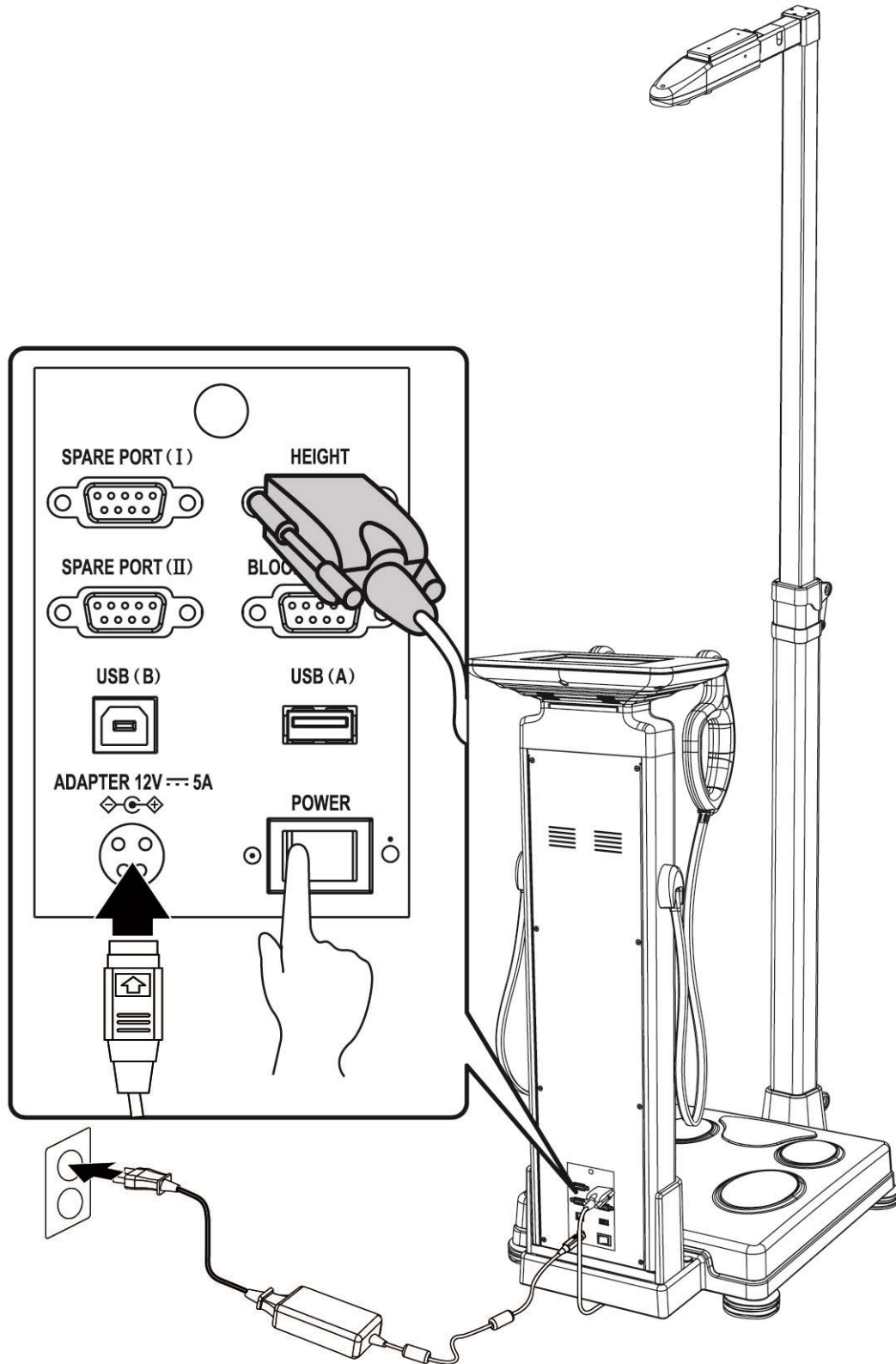

3. Assembling an Bluetooth (option)

Connect the provided Bluetooth to the BLUETOOTH port on the back side of the device.

Users can check and manage the result data on the exclusive mobile device app via Bluetooth connection.

① Components for Bluetooth

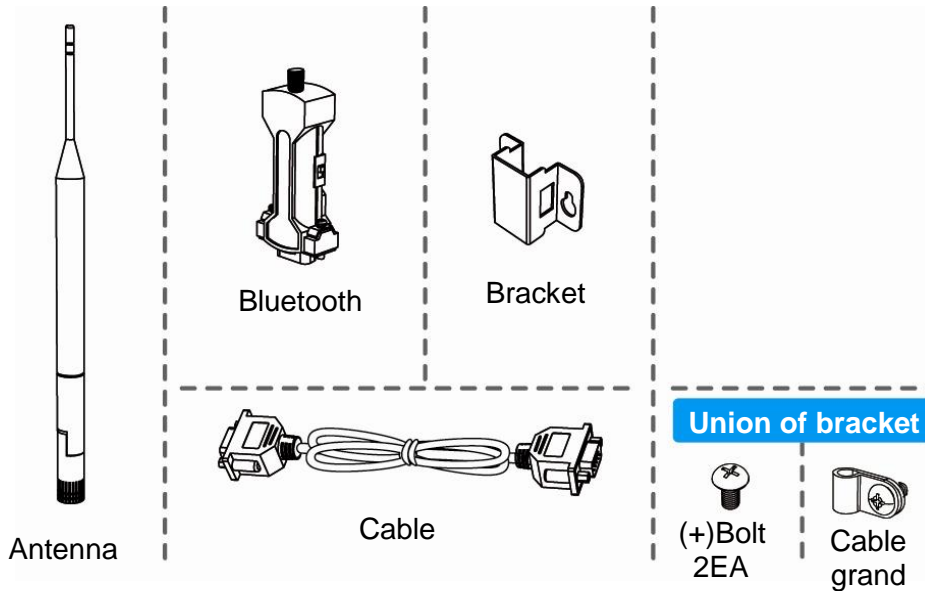

② Unscrew the (+) bolts (2EA) and cable grand (1EA) with a (+) driver. Keep the separate (+) bolts (2EA) and cable grand (1EA) to assemble a bracket and cable later.

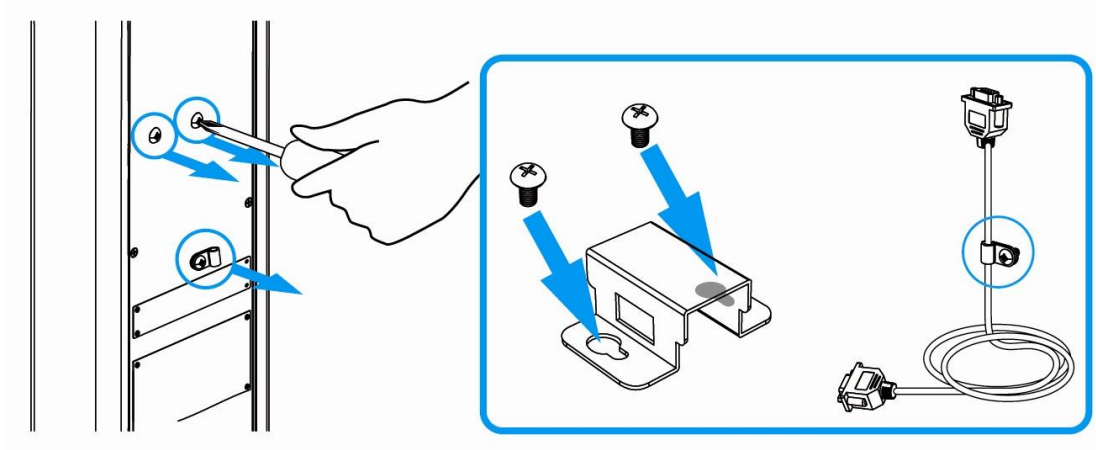

③ Connect the antenna to the Bluetooth.

Connect the main body connecting cable to the reverse side of the antenna and fix the cable by screwing the bolts in with a (-) driver.

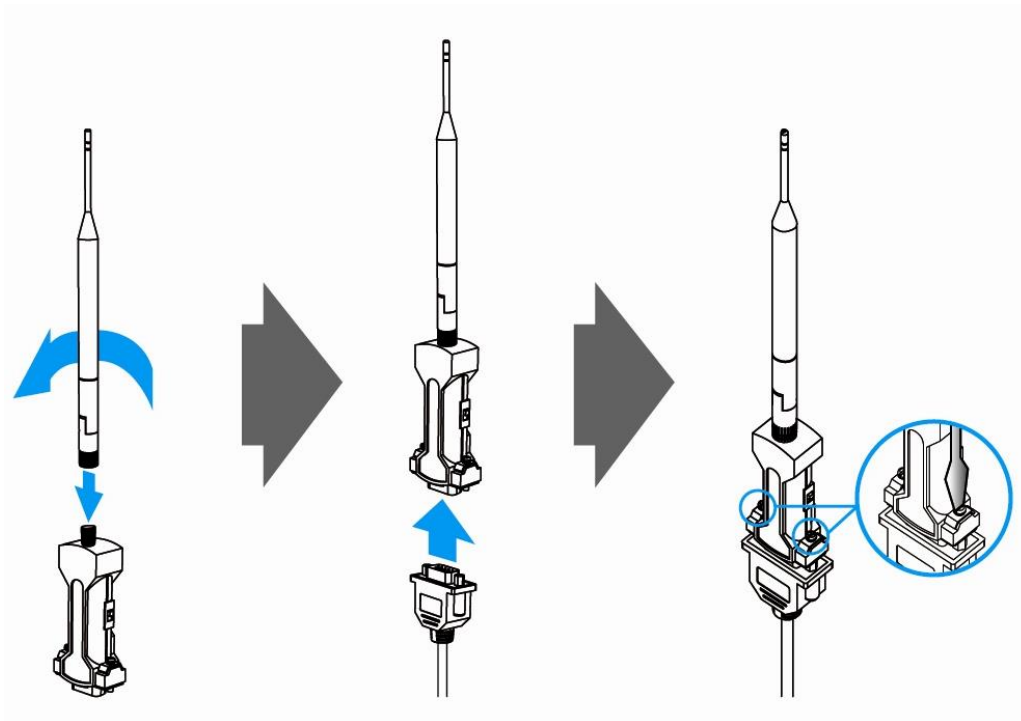

④ Connect the unconnected side of the cable to 'EXTERNAL PORT' on the back side of the main body and then switch on the Bluetooth.

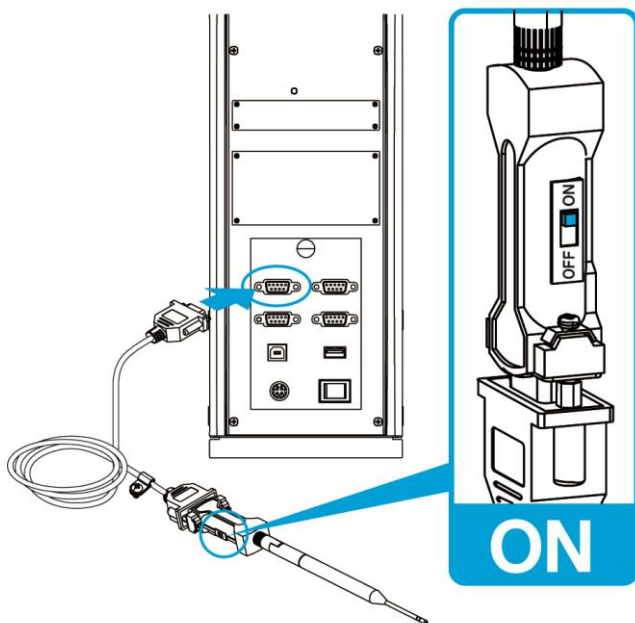

- ⑤ Fix the Bluetooth to the back side of the main body with the provided bracket using a (+) driver. The installation is completed by turning on the device.

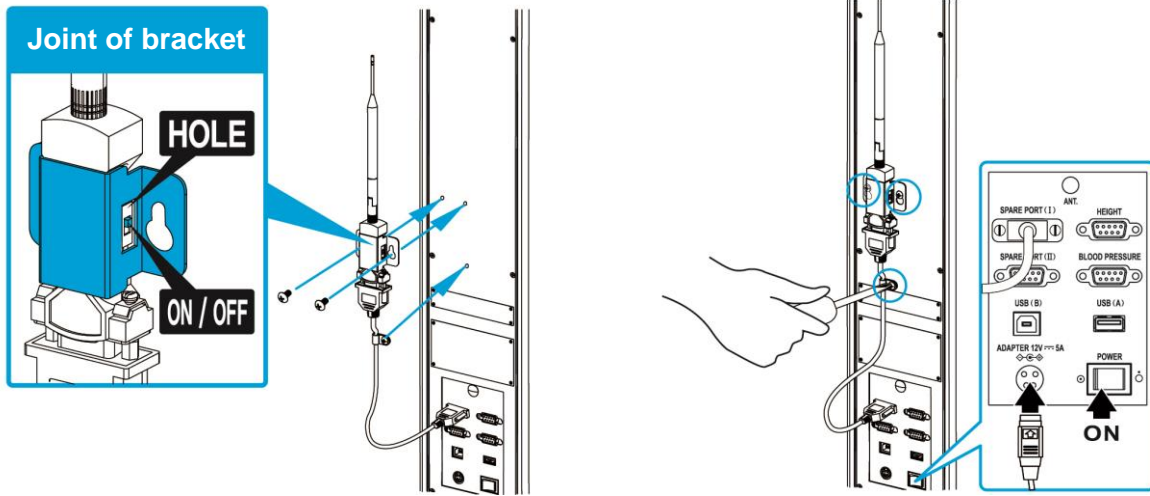

4. Assembling an ankle electrode (option)

When installing, packing and transporting, please work in teams of minimum 2 people to ensure safe operation.

(1) Components for installing an ankle electrode

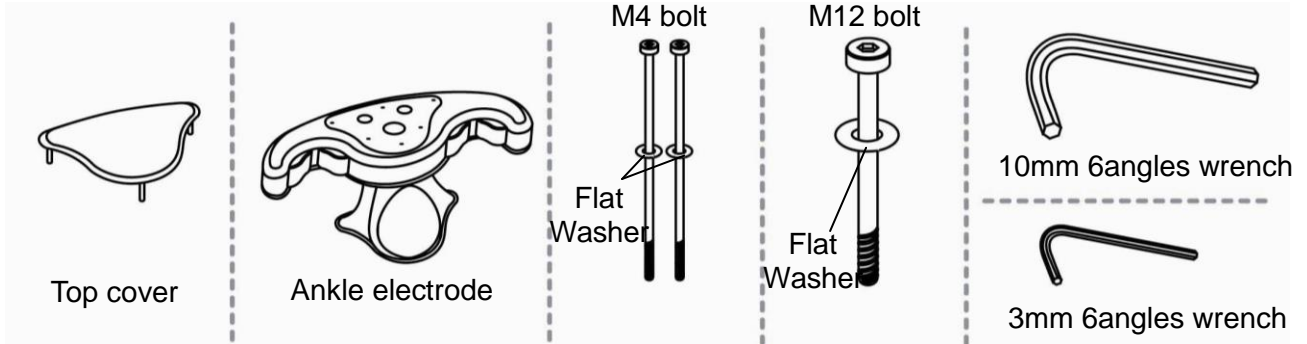

(2) Installing an ankle electrode

- ① Turn off the power of the device and disconnect the power cable before installing an ankle electrode.

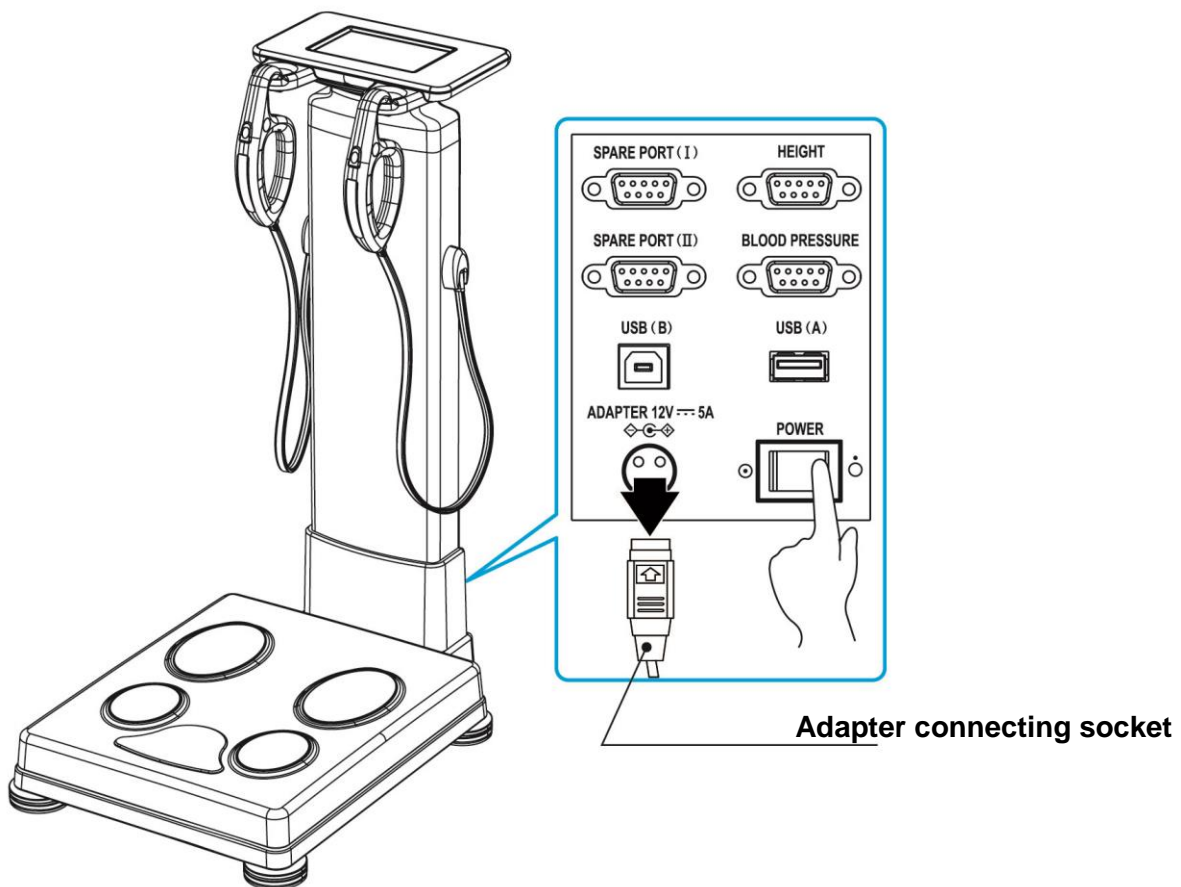

- ② Detach the top cover from the scale by using a (-) driver.



- ③ Check the RS-232C port of the weight scale and ankle electrode.

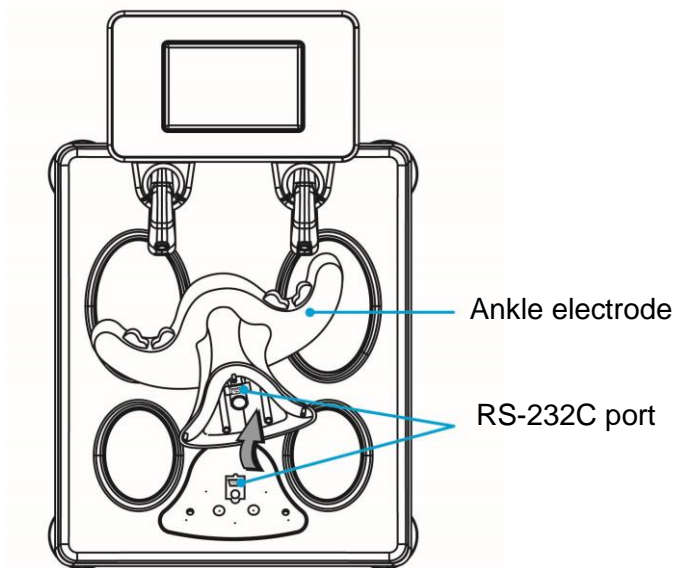

- ④ Connect the RS-232C port of the ankle electrode to the weight scale as shown in the picture.

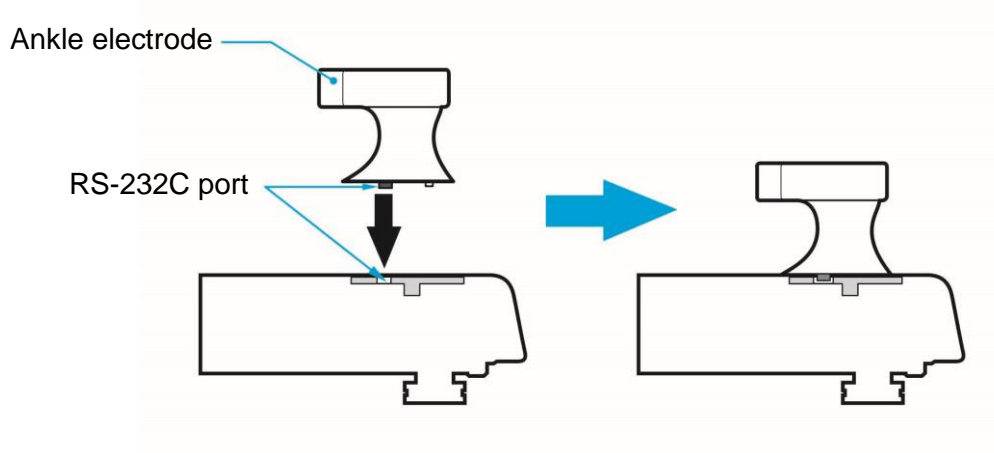

- ⑤ Grip the ankle electrode with one hand and fix it on the scale firmly by using M12 bolt-10mm 6 angle wrench and M4 bolt-3mm 6 angle wrench.

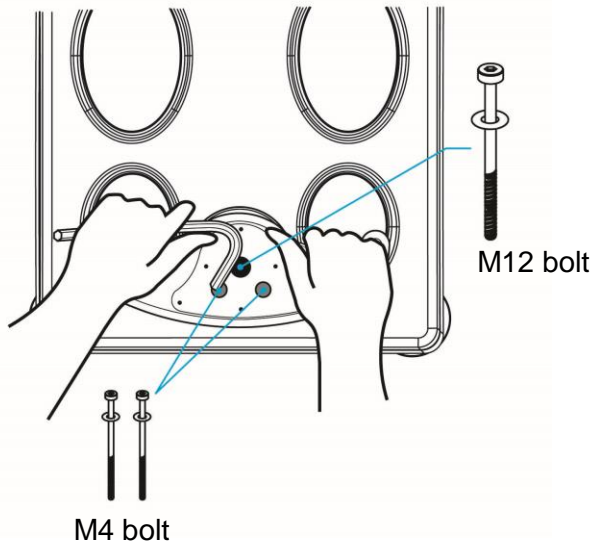

- ⑥ After that, try shaking the ankle electrode to check if the fixation is good or not.

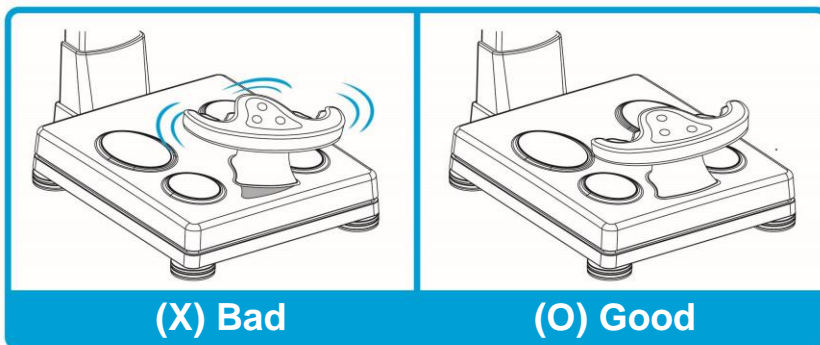

- ⑦ Remove the protective vinyl and double-faced sticker inside of the top cover.

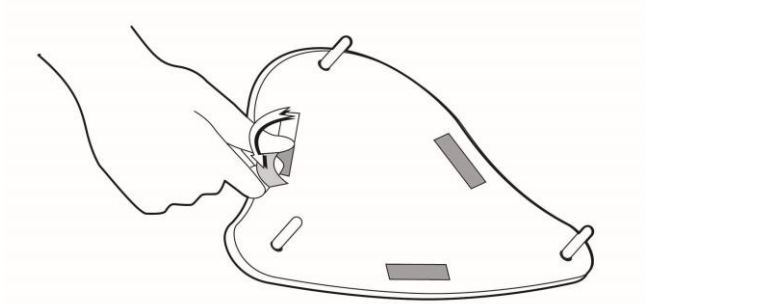

- ⑧ Attached the top cover on the ankle electrode to the arrow direction in the picture.

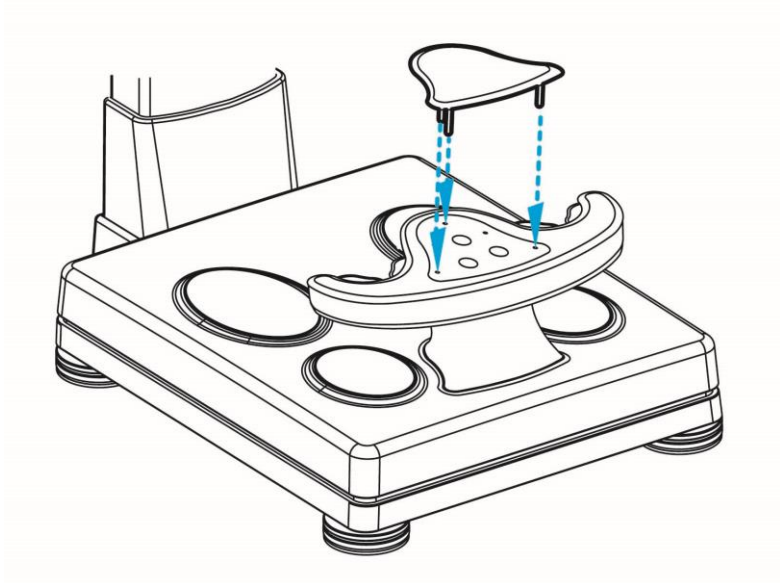

⑨ Power on

After finishing the installation, connect the adapter and power cable and turn on the device.

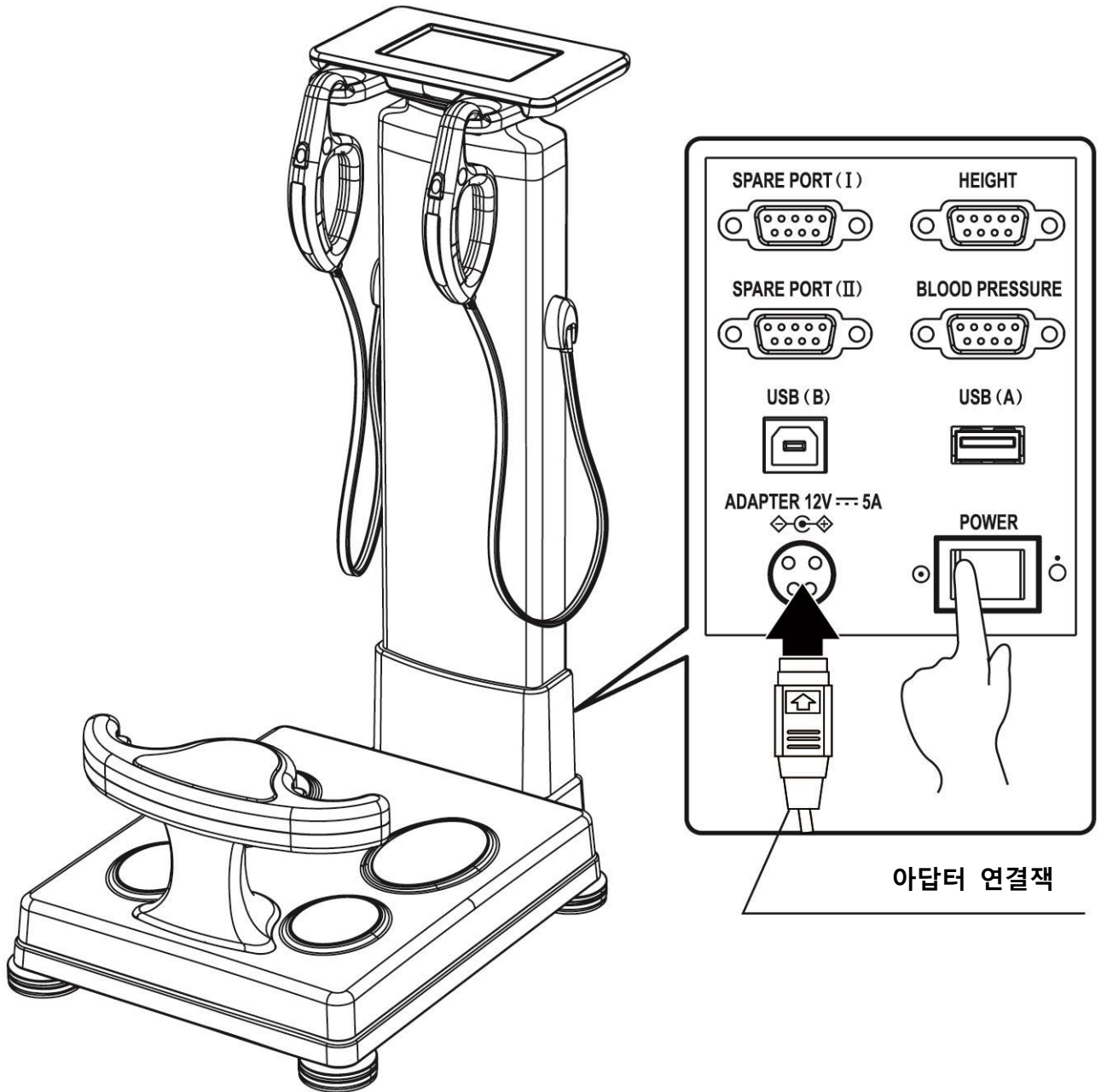

Periodic Check List

Management No. _____

Item		Inspection Subject	Requirements	Judgment	Remarks
Visual Check					
Mainframe	1	Enclosure	No scratch, crack, deformation and rust	Pass/Fail	
	2	Labels and panels	No peeling and dust	Pass/Fail	
	3	LCD	No damage	Pass/Fail	
	4	Electrode	No scratch and damage	Pass/Fail	
Accessories	1	Power cord	No scratch and damage	Pass/Fail	
	2	User manual	Kept in proper place	Pass/Fail	
Mechanical Check					
Mainframe	1	Keys	Smooth operation	Pass/Fail	
	2	Recorder	Smooth operation with no abnormal sound	Pass/Fail	
	3	Touch Screen	Smooth operation	Pass/Fail	
Accessories	1	Power cord	Smooth operation and removal	Pass/Fail	
Electrical Check					
Performance	1	Power supply	Screen display upon power-on	Pass/Fail	
	2	Display	No abnormality and flickering	Pass/Fail	
	3	Printing	printing possible	Pass/Fail	
	4	Measurement	Proper measurement	Pass/Fail	
General Judgment				Pass/Fail	
Model		ACCUNIQ BC510		Serial No.	
Installation place			Date of purchase		
Check date		Checked by		Approved by	

Copy this sheet for use

If repair is required, write down so in the Remarks column.

Daily Check List

Management No. _____

Item		Inspection Subject	Requirements	Judgment	Remarks
Visual Check					
Mainframe	1	Enclosure	No scratch, crack, deformation and rust	Pass/Fail	
	2	Labels and panels	No peeling and dust	Pass/Fail	
	3	LCD	No damage	Pass/Fail	
	4	Electrode	No scratch and damage	Pass/Fail	
Accessories	1	Power cord	No scratch and damage	Pass/Fail	
	2	User manual	Kept in proper place	Pass/Fail	
Mechanical Check					
Mainframe	1	Touch Screen	Smooth operation	Pass/Fail	
	2	Recorder	Smooth operation with no abnormal sound	Pass/Fail	
Accessories	1	Power cord	Smooth operation and removal	Pass/Fail	
Electrical Check					
Performance	1	Power supply	Screen display upon power-on	Pass/Fail	
	2	Display	No abnormality and flickering	Pass/Fail	
	3	Printing	Waveform printing possible	Pass/Fail	
	4	Measurement	Proper measurement	Pass/Fail	
Other	1	Clock	Present date/time	Pass/Fail	
General Judgment				Pass/Fail	
Model		ACCUNIQ BC510		Serial No.	
Installation place			Date of purchase		
Check date		Checked by	Approved by		

Copy this sheet for use

If repair is required, write down so in the Remarks column.



SELVAS Healthcare, Inc.

HEADQUARTERS:

155, Shinseong-ro, Yuseong-gu, Daejeon, 34109 Republic of Korea

TEL:82-42-879-3000 FAX:82-42-864-4462

SEOUL OFFICE (Sales):

20F Daerung Techno Town 18th, 19, Gasan digital 1-ro, Geumcheon-gu, Seoul, 08594, Republic of Korea

TEL:82-2-587-4056 FAX:82-2-588-1937

EUROPEAN REPRESENTATIVE:

VITAKO Sp. z o.o.

ul. Stanisława Żaryna 7c 02-593 Warszawa, POLAND

TEL: +48 505 522 888

If the problems continue, call the service center. When you ask for service, the manufacturer's label, serial number, date of original purchase and explanation of malfunction will be required.

Service center

**TEL : 02-587-4056
042-879-3000**

※ For purposes of improvement, specifications and design are subject to change without notice.



BC510E-20170918 Rev2.0